

Perfect Raw collection

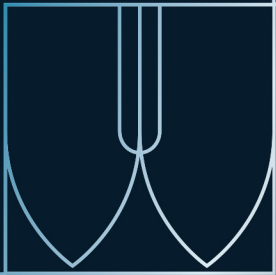

Unique by design
Crafted by people



greenapple

Welcome.

Greenapple designs and produces luxury furniture and bespoke projects for exclusive customers in Europe, Asia and North-America.

At our workshop, design is in tandem with the latest technological developments. This helps create a constant flow of new possibilities regarding creative ideas and material application methods. Fine craftsmanship, whether perfected by experienced hands or state-of-the-art machinery is equally quintessential in delivering top quality interior experiences.

From turnkey interior design projects, including delivery and installation, to luxury furniture design customisations, we cover a wide range of solutions for all kind of spaces.

Seasonally, we present unique collections with a variety of product typologies. We welcome you to explore the Perfect Raw collection.

Bem-vindo.

A Greenapple é uma marca de design de mobiliário de luxo com produção própria, que desenvolve também projetos de design de interiores para clientes exclusivos, nos mercados Europeu, Asiático e Norte-Americano.

No nosso centro de produção, o design, a inovação tecnológica e as técnicas artesanais de produção, funcionam em triade criando um fluxo contínuo

de ideias criativas e novos métodos de aplicações das nobres matérias-primas que usamos. A simbiose entre as mãos hábeis e experientes dos nossos artesãos e a ajuda da mais avançada tecnologia permite-nos criar experiências únicas e luxuosas em diversas tipologias de espaços interiores.

Desenvolvemos projetos completos de design de interiores, assegurando entrega e instalação

no local, mas também pequenos projetos de customização ou personalização das nossas peças de mobiliário.

Sazonalmente apresentamos coleções únicas com uma variedade ampla de produtos, percorra as páginas deste catálogo e descubra a coleção Perfect Raw.



Greenapple The story



Hi,
We are Greenapple
and we take things
personally.



A história da Greenapple

Olá,
Somos a Greenapple e para nós
tudo é pessoal.

São pessoas que estão no início,
meio e fim dos produtos e pro-
jetos que criamos.

Não somos contra produção
massiva de produtos, mas para
nós o cunho pessoal é essencial
no nosso processo criativo.

Explorar novos conceitos de raiz
e abraçar desafios impensáveis
é algo que está presente no
nosso ADN.

Para nós uma cadeira nunca
é apenas uma cadeira e um
projeto de interiores é muito
mais do que quatro paredes.
Ambos contam histórias de
materiais nobres, de uma
meticulosa atenção ao detalhe
e de acabamentos imaculados.

Trabalhamos cara-a-cara e
pomos (literalmente) as mãos-
à-obra no design, na manufatura,
na produção, no embalamento e

na entrega dos nossos produtos.
Há quem lhe chame um luxo.
Outros dizem que é uma loucura.
**Nós chamamos-lhe o método
Greenapple.**

People are at the beginning, middle and
end of the furniture and interiors we design.

We are not anti-mass-production, but we
find that personal touches are essential
in every creation.

Conceiving new concepts from scratch is our
lifeblood, and we have unthinkable challenges
written all over our DNA.

For us a chair is never just a chair and an interior
is much more than four walls. Both are stories
inspired and told by top-quality materials,
meticulous attention to detail, and timelessly
perfect finishings.

In each project we choose to be all-hands-
on-deck and face-to-face, as we insist upon
designing, crafting, producing, packing and
personally delivering our goods.

Some people call it a luxury.
Others call it madness.
We call it the Greenapple
way.



We, the people.

Glad to meet you.

We are Rute, Sérgio, Ana, Besiki, Carlos, Catarina, Cesário, Daniel, Daniel, Francisco, Henrique, Hugo, João, João, Luís, Manuel, Marcelo, Maria, Nuno, Paula, Pedro, Raquel, Rodrigo and Sofia.

Nós, as pessoas.

Muito prazer,
Nós somos a Rute, Sérgio, Ana,
Besiki, Carlos, Catarina, Cesário,
Daniel, Daniel, Francisco,
Henrique, Hugo, João, João,
Luís, Manuel, Marcelo, Maria,
Nuno, Paula, Pedro, Raquel,
Rodrigo e a Sofia.

Somos as pessoas que dão
vida à Greenapple.

We are the people that bring
Greenapple's creations to life.





Our story started in 2005 with Rute Martins and Sérgio Rebola, a couple of economists with MBAs and too many ideas to handle.

Little by little a family of 35 craftswomen and craftsmen began to assemble. Today the savoir-faire of ancient Portuguese workmanship always goes hand-in-hand with a restless tendency to innovate as we take on each unique project.

With our design and production unit in Portugal, we reach worldwide to customers in Europe, Asia and North-America markets.



Here we source our wood, stone, design, make, dedication and distribute the entire Greenapple's product range.

A nossa história começa em 2005 com Rute Martins e Sérgio Rebola, um casal de economistas com MBAs e muitas ideias entre mãos.

A pouco e pouco juntámos uma família de 35 artesãos e designers. Hoje o legado ancestral de técnicas artesanais portuguesas, anda de mãos dadas com a inovação e design em cada projeto.

Com o nosso centro de produção e design em Portugal, fazemos chegar as nossas criações a qualquer ponto do mundo. É a partir daqui que obtemos os materiais nobres, o design, a produção, a dedicação e distribuímos a nossa gama de produtos e serviços.

Atualmente temos consolidada uma forte presença nos mercados Europeu, Asiático e Norte-Americano.

First, we are all ears.

As our customers drop hints about their dream homes and projects, we pick them up and go straight to the drawing board.

Then we are all minds,

brainstorming ideas back and forth between designers, master carpenters, upholsters, stonemasons and, eventually, you.



Soon thereafter we are all hands.

Skilled and talented hands, that are essential to deliver a bespoke expertise (and personality) to every detail of the finished piece.

Finally,

we conclude with a 'thank you' in the shape of a handshake, hoping to see you soon.



Primeiro, ouvimos.

Quando os nossos clientes nos revelam as suas ideias e sonhos, ouvimos e começamos a pesquisar.

Depois, criamos.

Mergulhamos em turbilhões de ideias entre designers, mestres carpinteiros, estofadores, mestres marceneiros e o nosso cliente.



E pouco depois metemos mãos à obra.

Mãos talentosas e especializadas essenciais ao perfeccionismo e detalhe presente em cada produto.

Finalmente, concluímos com um 'obrigado' na forma de um aperto de mão, e com a expectativa de nos encontrarmos novamente.





In Good Hands

Welcome to our workshop.

Having our own in-house production makes a world of difference.

Em boas mãos Bem-vindo à nossa oficina

O facto de possuímos a nossa própria produção faz toda a diferença.

Permite-nos ser obcecados com cada detalhe e verificar e re-verificar e voltar a re-verificar cada criação.

Dá-nos liberdade para uma entrega e dedicação total aos exigentes projetos customizados e feitos à medida do cliente.

Permite-nos garantir um padrão de alta qualidade durante todo o processo, desde o design à produção, e da produção até à sua porta.

It allows us to be obsessed with detail, carefully checking and rechecking and re-rechecking every creation.

It gives us the freedom to dedicate ourselves to the most demanding tailor-made and customised work.

It lets us assure high-quality standards through the whole process, from design to production, from production to your home.

And it allows no excuses. Because we control all production timings, if there's anything unforeseen (knock on wood) we are solely responsible.

Greenapple's production centre works both as an experimental laboratory and a well-oiled family facility with no loose ends.

Noble materials and cutting-edge technology, experienced craftsmanship and innovative methods, soulful spaces and flawless work: that's what we deliver.

Drop by for a visit and see for yourself how we're taking what really matters into our own hands.

E não nos deixa margem para desculpas. Como controlamos todas as etapas, se existir algum imprevisto (bata na madeira) seremos só nós os responsáveis.

O centro de produção Greenapple é simultaneamente um inovador laboratório experimental e uma oficina familiar com larga experiência.

Materiais nobres e tecnologia avançada, artesãos experientes e métodos inovadores, espaços inspiradores e peças ímpares, é aquilo que entregamos.

Visite-nos e veja como o seu projeto fica entregue em boas mãos.

We, the hands.

Daniel Mata Woodsmith

He was the first woodworker to become part of our team. His earliest passion for wood began when he was 13 years old, and he built a train with his own hands. In that moment he decided the career he would pursue. Along with his planers, filers, rasps and gouges, always aligned, he applies his mastery with a degree of technical refinement that is fully recognized only by those with high visual and tactile sensibility. Daniel is a fierce advocate of the eternal improvement of craftsmanship.

Daniel Mata Marceneiro

Foi o primeiro marceneiro a fazer parte da nossa equipa. A sua paixão pela madeira começou aos 13 anos quando construiu um comboio com as suas próprias mãos. Decidiu nesse momento o ofício que iria seguir. Junto às suas plainas, limas, grosas e goivas, sempre alinhadas, aplica diariamente a sua mestria em peças de elevada exigência técnica, reconhecida apenas por quem possui visão e tacto apurados. Daniel é um acérrimo defensor do eterno aperfeiçoamento.

Leandro Almeida Upholsterer

By observing the pieces from the master upholsterer of this house, we are faced with a non-conformist who refuses to neglect even the smallest detail. Wrapped in the silence of the handling of fabrics, Leandro reveals: "the secret of upholstery is to apply the padding well, and to make perfect seams." He likes to teach his craft to new apprentices, but he knows that it can take an entire lifetime to reach perfection, especially in the case of the most difficult raw material to dominate: "with the leather, it's necessary to know how much we give of ourselves, and how much it gives of itself."

Leandro Almeida Estofador

Pelas peças do mestre estofador desta casa, percebemos que estamos perante um inconformista que não descarta o mais mínimo detalhe. Envolvido pelo silêncio do manuseamento dos tecidos Leandro revela: "o segredo de um estofa é aplicar bem as espumas e fazer costuras perfeitas." Gosta de ensinar o seu mister aos novos aprendizes, mas sabe que perfeição pode demorar uma vida inteira a atingir, especialmente no caso da matéria-prima mais difícil de domar: "com a pele é preciso saber quanto damos de nós e quanto ela dá de si."

Ana Gaspar Finishing specialist

When a particular armchair or mirror leaves the workshop where they were created, they are only apparently finished: they still must pass through the hands of Ana, a specialist in "elevating" pieces of design and dressing them with a new skin. Dealing with fine flakes of gold and silver requires concentration, technique and a controlled environment where not even the slightest breeze can enter. It is an extremely delicate and dedicated task, and for an instant it seems like time stops for this art to be applied in a truly masterful way - as the gold, the silver and the connoisseurs of timeless creations demand.

Ana Gaspar Acabamentos

Quando um certo cadeirão ou espelho saem das oficinas onde foram criados estão só aparentemente terminados, precisam ainda de passar pelas mãos da Ana, especialista em "eivar" as peças de design e vesti-las com uma nova pele. Lidar com as finas folhas de ouro e de prata requer concentração, técnica e um ambiente controlado onde não pode correr uma brisa sequer. É um trabalho de extrema delicadeza e dedicação, por um instante parece que o tempo pára para que esta arte seja aplicada de forma magistral, tal como o ouro, a prata e os apreciadores de criações intemporais o exigem.



A Matter of Trust

Every human interaction is a stepping stone towards creating something truly original and unique.



Great customer care calls for time and dedication, so we invest.

Uma relação de confiança

Em cada interação humana existe a oportunidade para criar algo único e original.

Na Greenapple colaboramos constantemente com artistas, designers e arquitetos para quem oferecemos soluções únicas, desde projetos chave na mão com entrega e montagem, a serviços e objetos personalizados ou customizados.

Investimos todo o nosso tempo e dedicação na atenção e satisfação do cliente.

O perfeccionismo e a atenção ao detalhe – desde a idealização até à instalação do projeto – fazem parte da nossa natureza.

Here at Greenapple we constantly work with interior designers, architects, artists and creative people to whom we provide a full range of services, from a turnkey project, including delivery and on-site installation, to individual services, such as design customisation or personalised objects.

It is in our own very nature to follow through each design stage down to the last detail.



Crafting the Bongó, the Story

The unique musicality shape of the Bongó bar cabinet leaves no one indifferent. Like the echo of a drum, its elegance and handcrafted excellence reverberate throughout any room or space in your home or business. With its distinctive design and quality materials, every detail is carefully handcrafted in our factory to ensure a striking presence and unparalleled excellence of the final product.

We invite you to join us on a success story of endless passion and greatest attention to detail in the making of the Bongó cabinet bar.

Bongó, a história

A musicalidade implícita na forma do móvel bar Bongó não deixa ninguém indiferente. A sua elegância e perfeição produzidas pelas mãos dos nossos artesãos, ressoam em qualquer espaço como um eco de um tambor — seja numa casa, num escritório ou num lobby de hotel.

Com o distinto design e a qualidade das nobres matérias-primas, cada detalhe do Bongó é trabalhado meticulosamente no nosso centro de produção, assegurando uma presença impactante e singular do produto final.

Convidamo-lo a descobrir esta história de sucesso motivada por uma grande paixão, capacidade de entrega, obsessão pelo perfeccionismo e atenção ao detalhe na concretização do móvel bar Bongó.





The inspiration

Insight leads to intuition and revelation. Slowly but steadily a story starts taking shape in the creative mind where scenery, architecture, fashion and lifestyle must all play their part.

The initial conceptual motif was for the object to evoke feelings of relaxation and exuberance that celebrated the pleasure of living and enjoying life.

A inspiração

A observação dá origem à intuição e à revelação. Lenta, mas firmemente uma história começa a ganhar forma na mente criativa, onde referências como o contexto, a arquitetura, a moda e as tendências assumem um papel.

A inspiração inicial pretendeu incutir no objeto emoções de relaxamento e exuberância, celebrando assim o prazer da vida.

Conceção da ideia

Sessões de brainstorming formam a base daquilo que agora se torna mais palpável. É neste momento que pedimos que todos intervenham, que designers, mestres carpinteiros e marceneiros ponham as mãos na massa, e assim comecem a projetar soluções de design e produção do Bongó.

Estas soluções desenvolvem-se em sucessivas iterações entre criadores e executores até ao ponto que sejam possíveis de ser concretizadas.

Este é o momento em que começamos a materializar o sonho.

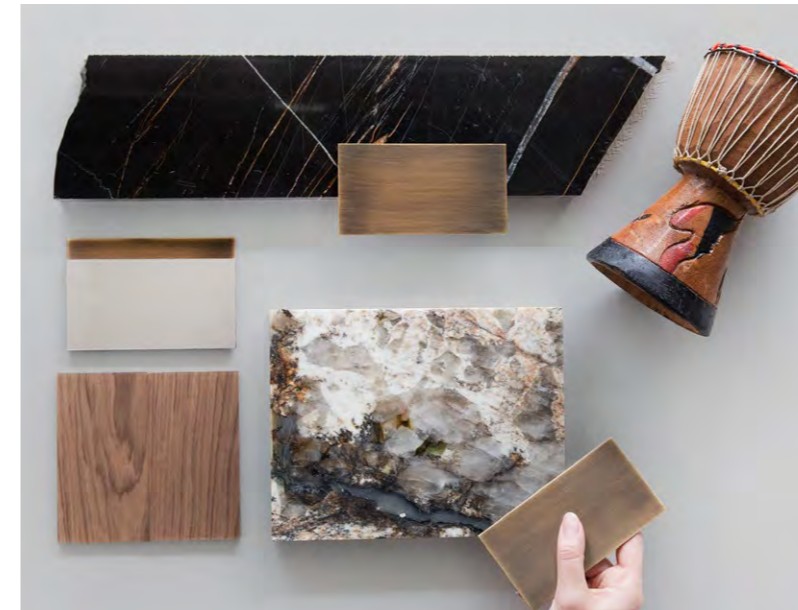

The problem solving

With all great achievements comes great challenges. The elegant and seductive drum shape of the cabinet along with its impressive sliding Sahara Noir marble doors meant that the overall structure, mechanisms and material applications had to be aligned with the latest technological developments. A challenge fully accepted by Greenapple's in-house team.

A resolução do problema

Grandes conquistas são alcançadas com grandes desafios.

A elegante e sedutora forma de tambor do Bongó, juntamente com as suas imponentes portas deslizantes em mármore Sahara Noir implicou que toda a sua estrutura, mecanismos e materiais fossem ao encontro dos desenvolvimentos tecnológicos mais recentes. Um desafio totalmente aceite pela nossa equipa.

The ideation

Continuous brainstorming sessions lay the foundations for what is now becoming more tangible. This is the stage where we ask everyone to get on board. Designers, carpenters, cabinetmakers, woodworkers with all hands-on deck, start working out possible solutions to the Bongó design and production elements.

Ideation concepts bounce back and forward between makers, crafters and creators up to a point where feasibility is possible. This is when we start materializing a dream.





A solução

Simplicidade não é algo simples.

O modo particular de fazer deslizar as extraordinárias portas em mármore Sahara Noir, foi conseguido através de um mecanismo feito à medida para este produto, assegurando assim um suave manuseio.

Sensores de movimento e deteção de pressão localizados dentro dos puxadores tornam possível uma abertura de portas automática. Sensores infravermelhos conferem um mecanismo de auto encerramento seguro. As recentes inovações tecnológicas em corte de pedras, foram aqui fundamentais para reduzir a espessura e respetivo peso das portas tornando possível uma abertura total. Com a abertura das portas, é acionado automaticamente a retroiluminação do fundo interior do móvel em Granito da Patagónia, evidenciando assim a textura da pedra e criando um efeito surpreendente.

The solution

To be simple is no small matter.

A special state of the art sliding door mechanism was tailored specifically for Bongó to assure a safe and smooth handling of the spectacular Sahara Noir stone doors. Motion and pressure detection sensors located within hand's reach were added in order to deliver a full experience of an automated door opening. Infrared sensors installed, assure a safe-self closing mechanism.

In addition to that, the latest technologies in stone cutting were fundamental in reducing thickness and therefore overall weight of the doors. Automatic light switches were hidden from plain sight in the frame, allowing the Patagonia Granite stone texture to shine from within.

The craft at work

Ultimately, a prototype phase was conducted in which every detail was painstakingly tested and optimised, by our quality control team, to meet the industry standards.

One could now fully grasp the sheer impact of a real size Bongó as its essence started to slowly become unmistakably present in the surrounding space.

A habilidade do ofício

A fase de protótipo é minuciosamente testada e otimizada até ao último detalhe, pela equipa de controlo de qualidade para garantir as exigências de um produto de luxo.



The choice of materials, construction and execution in the Bongó making is pursued without compromise and represent the finest in quality when it comes to combining modern production methods with expert craftsmanship. Having development, design and production stages all under one roof, is what makes Greenapple's product stand out from our direct competitors.

A escolha dos materiais nobres, a qualidade da construção e a perfeição dos acabamentos do Bongó espelham a simbiose eficaz entre os métodos modernos de produção e a mãos especializadas dos nossos mestres artesãos. Ter todas as

The following production stages embody the spirit of the handcrafted excellency in the making of the Bongó cabinet bar.

fases, desde a criação até à embalagem do produto, sob o mesmo teto é o que nos diferencia da concorrência, dando-nos a capacidade de controlar todos os pormenores de qualidade e tempos de produção.

As seguintes etapas de produção demonstram a habilidade e o perfeccionismo do espírito artesão patentes no móvel bar Bongó.



Frame work bending

Long strips of wood are layered and carefully glued to produce the perfect arc curve. This is a 100 percent handmade process that uses five skilled pair of hands and takes up to 5 days to conclude. Due to seasonal changes in temperature this process is required to take place in specific month intervals throughout the year. The finishing result is a frame which provides strength and ensures stability for the following stages.

Cabinet parts production

A robust bespoke sliding door mechanism is produced in metal providing a smooth operation to the user. The sliding mechanism, apart from being totally invisible, has a soft close feature and it is entirely developed by Greenapple. Simultaneously, the legs and door handles in oxidised brass are manually produced and then undergo also a manual process of surface finishing.

A shelving unit in walnut veneer with its beautiful wood grain is prepared for the cabinet assembly.

Door module and stone application

Because each design component is carefully designed to deliver an exclusive experience, the sliding doors are made to fit, down to the millimetre, leaving no mismatches nor awkward gaps between mating parts.

Each individual stone with its beautiful, intricate veins is personally selected from our trusted manufacturers and delicately sliced using the latest cutting technologies into a thin yet durable

Produção e moldagem da estrutura circular

Para criar a curva perfeita da estrutura circular, longas placas de madeira flexionadas contra um molde são acamadas e cuidadosamente coladas. Este processo é 100% realizado manualmente, sendo precisos cinco habilidosos pares de mãos, o que leva, ainda assim, mais de 5 dias para o concluir.

Devido às diferentes temperaturas sazonais, este processo requer cuidados especiais e intervalos mensais específicos ao longo do ano em que pode ser realizado. O resultado final é uma estrutura ultra resistente, que garante estabilidade para as etapas seguintes.

Produção dos restantes elementos

O robusto mecanismo de porta deslizante foi desenvolvido pela Greenapple especificamente para o Bongó tendo em conta o peso das suas portas em mármore. Este mecanismo em metal permite um manuseamento fluido e sem esforço e está totalmente escondido dentro do móvel.

Simultaneamente são produzidas as pernas e os puxadores em bronze oxidado, cuja execução é totalmente manual até à fase de acabamento do metal.

Por esta altura, o módulo interior do móvel em folha de nogueira com acabamento mate está pronto para a montagem final das partes.





sheet of stone. Soon after this, the stone is perfectly and seamlessly incorporated into the door structure along with its bespoke automated sliding mechanism.

Electrics, Painting and assembly

Now that all important elements are produced, light fixtures are installed inside the frame so that no electrical elements remain visible. The cabinet parts enter then a lacquering booth, where non-toxic high quality paints are manually sprayed onto the frame and doors. Coating and finishing is a process that takes about a week to complete. This assures a smooth and seamless coat of paint to endure even after generations of use.

Finally the work passes to the assembly shop where every Bongó element is put together and final testings are conducted under a precise and rigorous supervision.



Módulo da porta e aplicação da pedra

Tal como cada componente, cuidadosamente desenhado e criado para produzir uma experiência de exclusividade, também as portas são feitas ao milímetro, não deixando qualquer imperfeição ou discrepância na ligação das partes.

Cada pedra com a sua textura única é selecionada pessoalmente pelos nossos designers aos nossos fornecedores de confiança. Recentes tecnologias de corte de pedra permitem fatias incrivelmente finas, mas ainda assim, resistentes. De seguida, esta fina fatia de pedra é perfeitamente incorporada na estrutura metálica da porta, assim como o seu mecanismo de deslizar automático.

Instalação elétrica, pintura e montagem final

Agora que os elementos essenciais estão concluídos, a iluminação é instalada de forma a que nenhum dos componentes elétricos fique visível. Simultaneamente inicia-se o



processo de lacagem em que tintas de alta qualidade, não tóxicas são manualmente aplicadas na estrutura e nas portas. Este é um processo moroso que pode chegar até uma semana para se concluir, contudo é essencial para garantir uma pintura uniforme, resistente e que perdure no tempo.

Finalmente, segue-se a fase da montagem final, em que cada elemento do Bongó é preparado, testado e supervisionado com rigor e precisão.

Pronto para envio

A forma expressiva e elegante do Bongó depende de um cuidadoso trabalho e esforço de hábeis mãos em que cada detalhe, etapa e processo, fazem diferença na experiência que queremos que o Bongó proporcione. Como tal, é absolutamente essencial que o Bongó esteja seguro e bem acondicionado, para que chegue ao seu destino, em qualquer parte do mundo, de forma irrepreensível e nas condições perfeitas.

Off to Shipping

The expressive, yet elegant shape of Bongó depends on the careful work and effort of skilled craftsmen, where every stage, process or detail matters.

This why it is absolutely essential that your Bongó is secure and neatly packaged so that it arrives anywhere in the world in impeccable shape and mint condition.

Perfect Raw collection

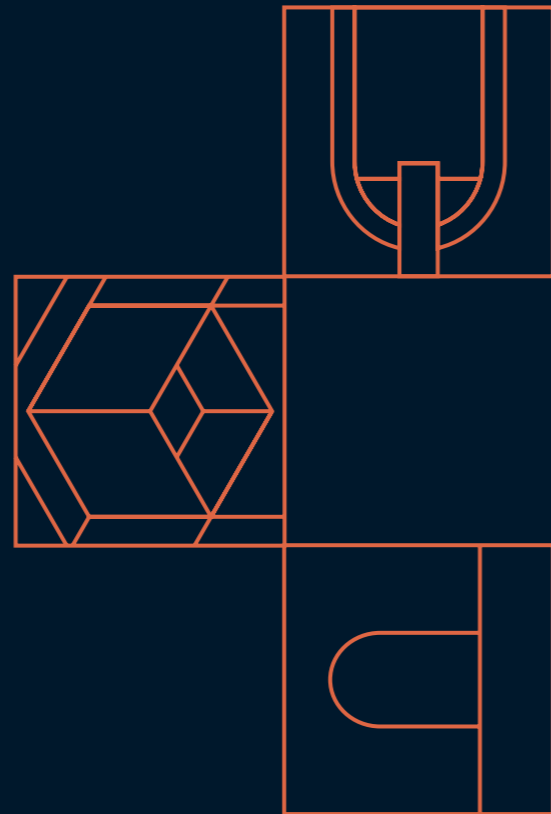

Perfect Raw exquisite pieces are sumptuous and elegant, like nature is.

Nature's elements are the primeval inspiration, fire, earth, air, water, metal and wood. Then the purest structures of architecture come along: dolmens, domes, towers, aqueducts and bridges. We give them form, meaning and expression, by shaping them into a clear identity.

The collection Perfect Raw embodies a combined effort between designers creativity and artisans savoir faire, enhancing finishes and textures in a game between perfectionism and raw beauty from which simplicity emerges as the ultimate form of sophistication.

Os elementos naturais são a nossa matéria-prima: fogo, terra, ar, água, metal e madeira. Procuramos inspiração na mais pura das expressões arquitetónicas – dólmenes, cúpulas, torres, aquedutos e pontes – conferindo-lhes de seguida forma, significado e expressão, moldando assim uma identidade.

Esta coleção resulta de uma simbiose criativa entre os nossos designers e o savoir faire dos nossos mestres artesãos, enaltecendo os materiais naturais e acabamentos num jogo entre a perfeição e a beleza crua, em que a simplicidade surge como a melhor forma de sofisticação.

Perfect Raw reúne uma coleção de peças elegantes e sumptuosas, tal como a natureza.

Cabinets & Bookcases
74–91

Sideboards
92–105

Tables & Consoles
106–131

Low tables
132–171

Seating
172–245

Lighting
246–265

Complements
266–285

Technical info 286–311



A light green upholstered chair with a curved backrest and four legs, positioned to the left of the table.

A round table with a white top and a wooden base, featuring a textured white side panel and a curved metal leg. Two small glass vessels are placed on the table.

A light green upholstered chair with a curved backrest and four legs, positioned to the right of the table.

Two modern pendant lights with gold-colored stems and white, semi-circular shades, hanging from the ceiling.

A wall with vertical dark wood slats, featuring an arched opening on the right side that allows bright light to enter.

A wall with a textured, orange-brown finish, curving around the left and back of the table area.

A dark grey, polished floor with a curved, raised platform area where the table and chairs are placed.

















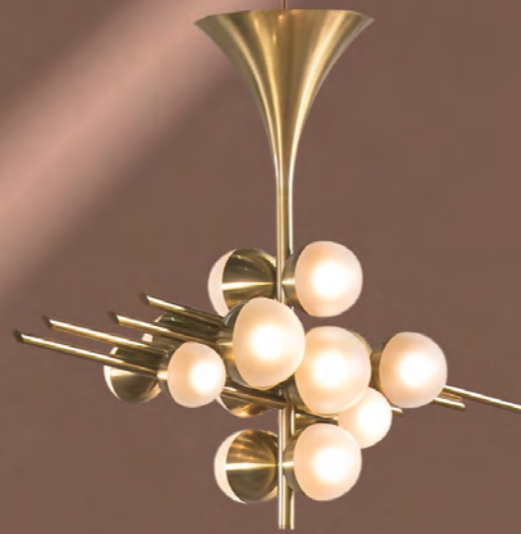

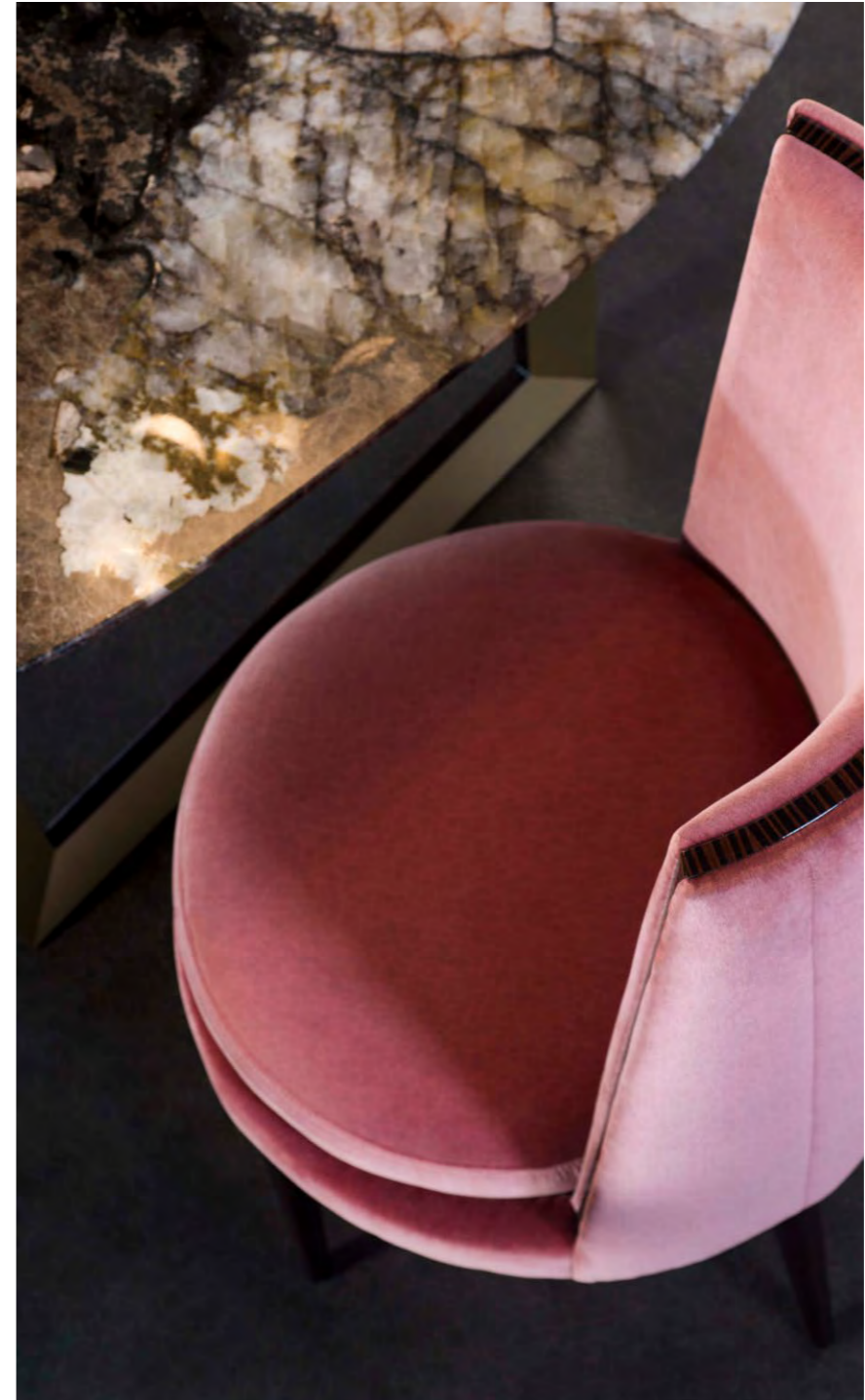

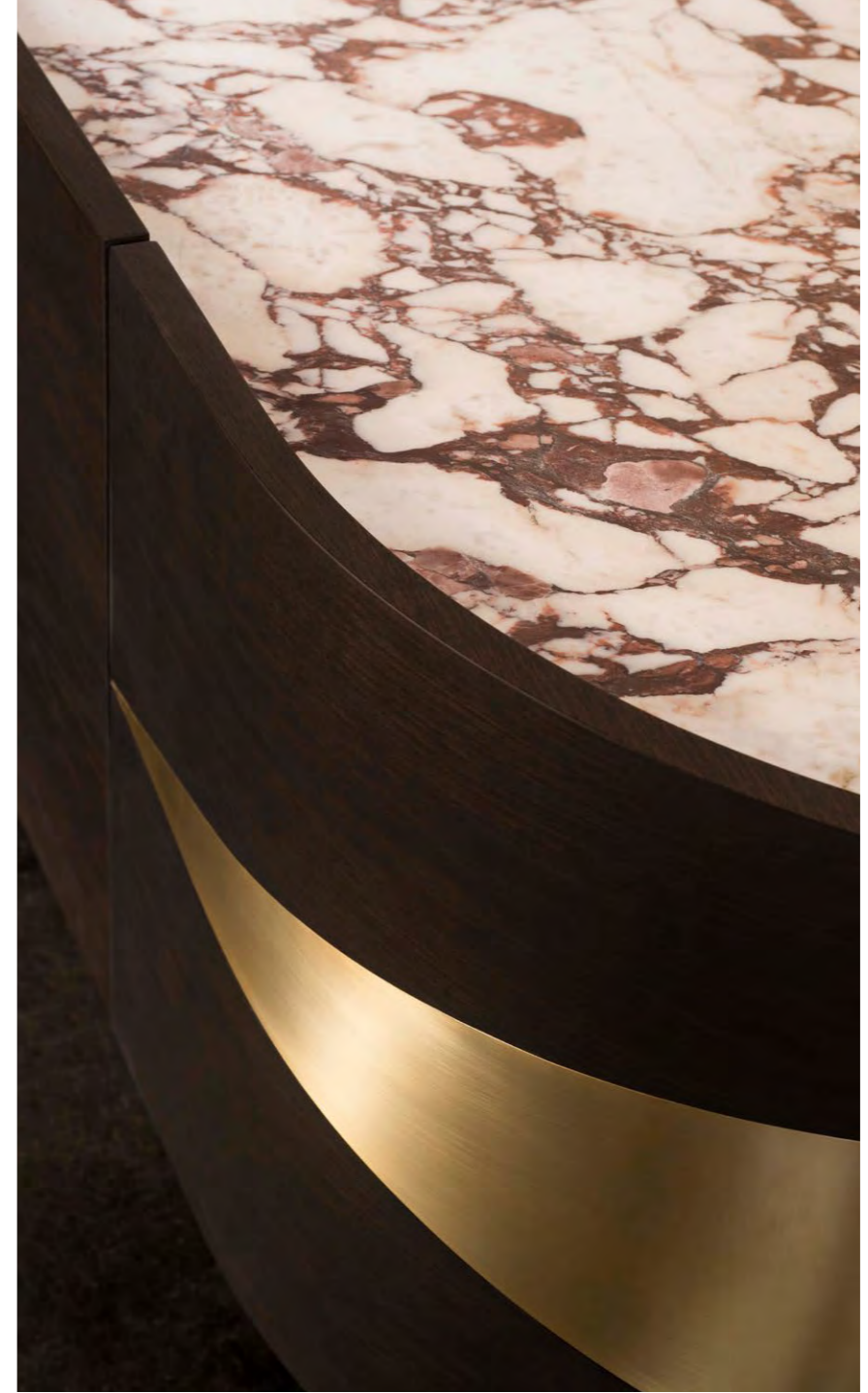



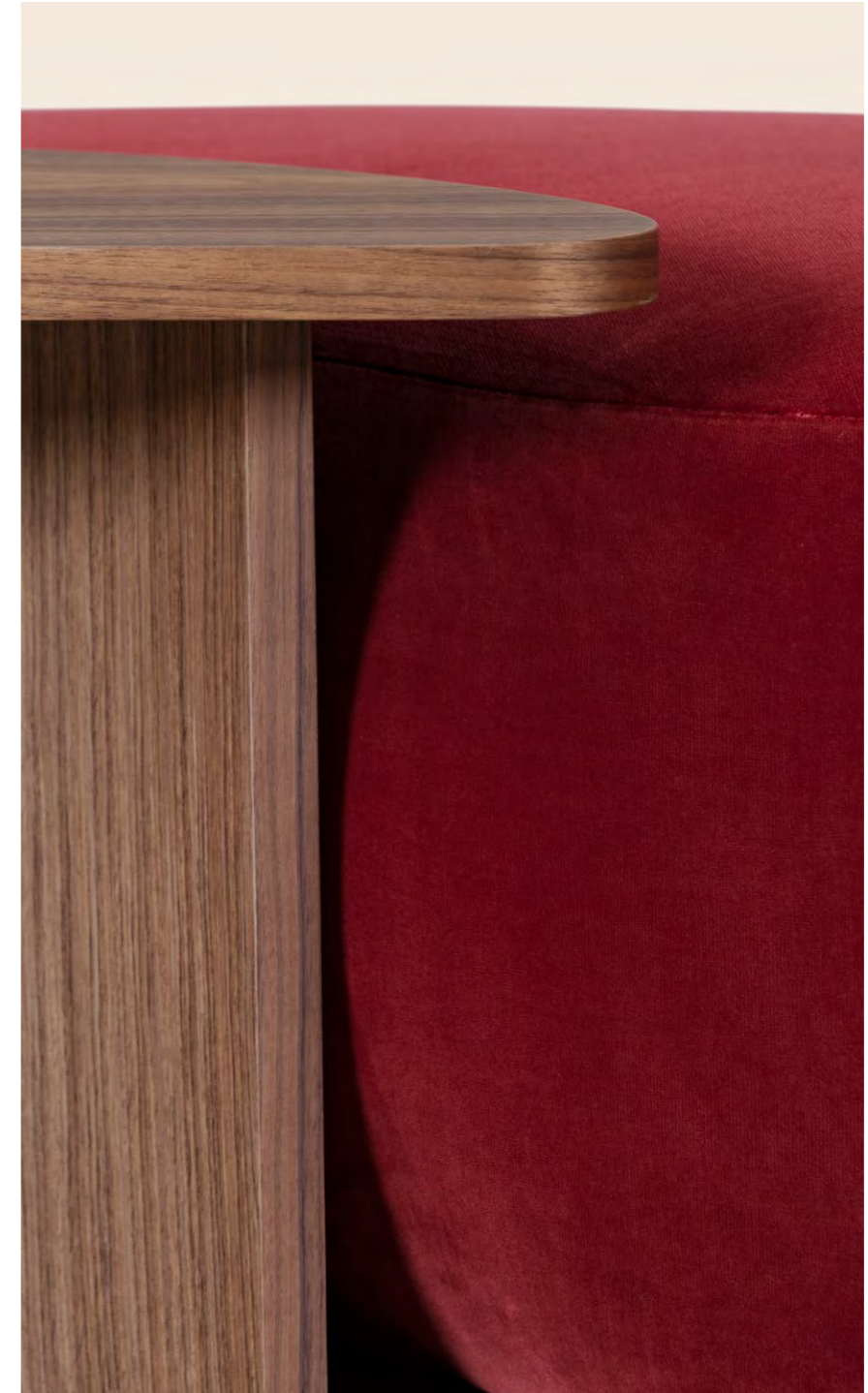

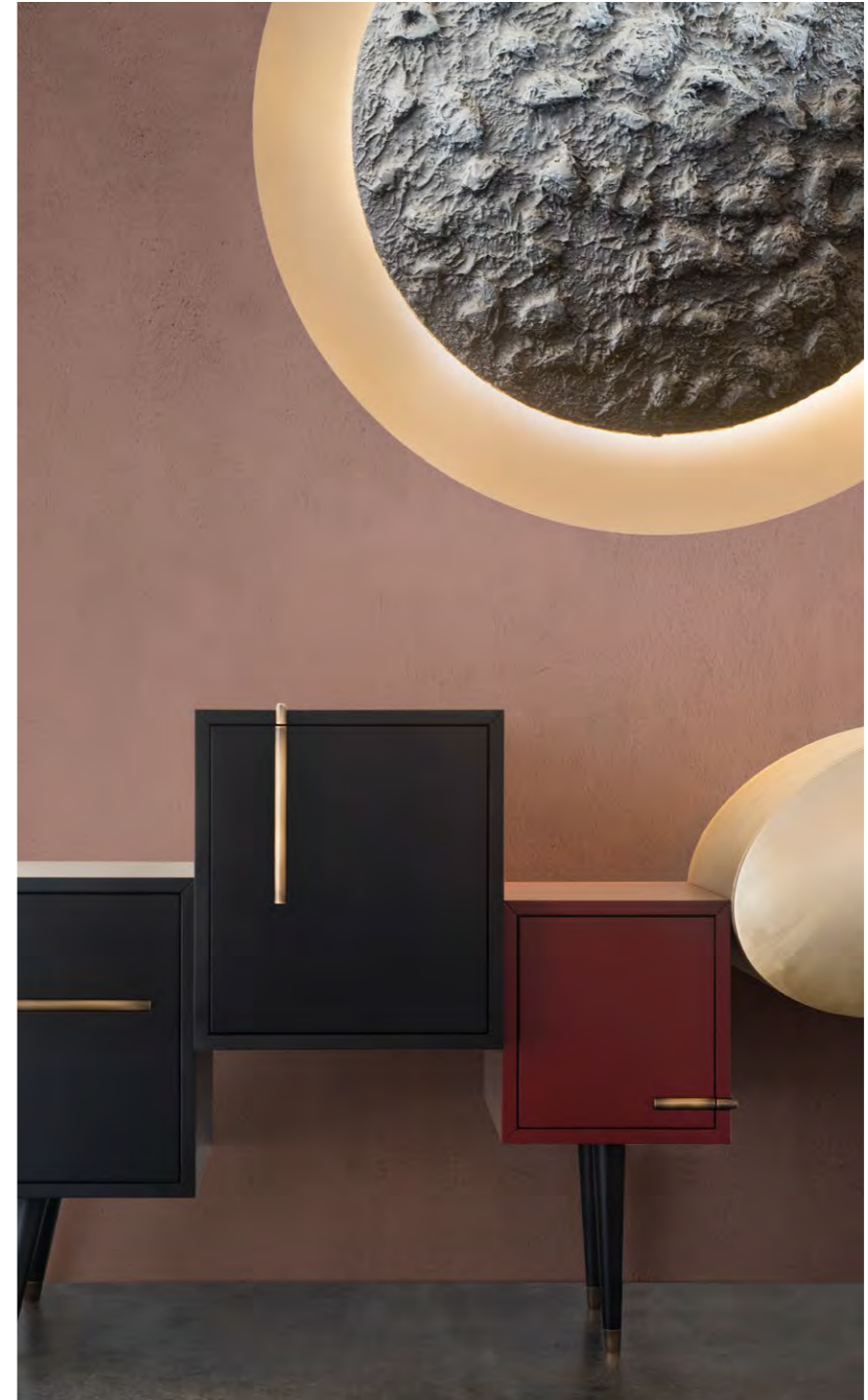



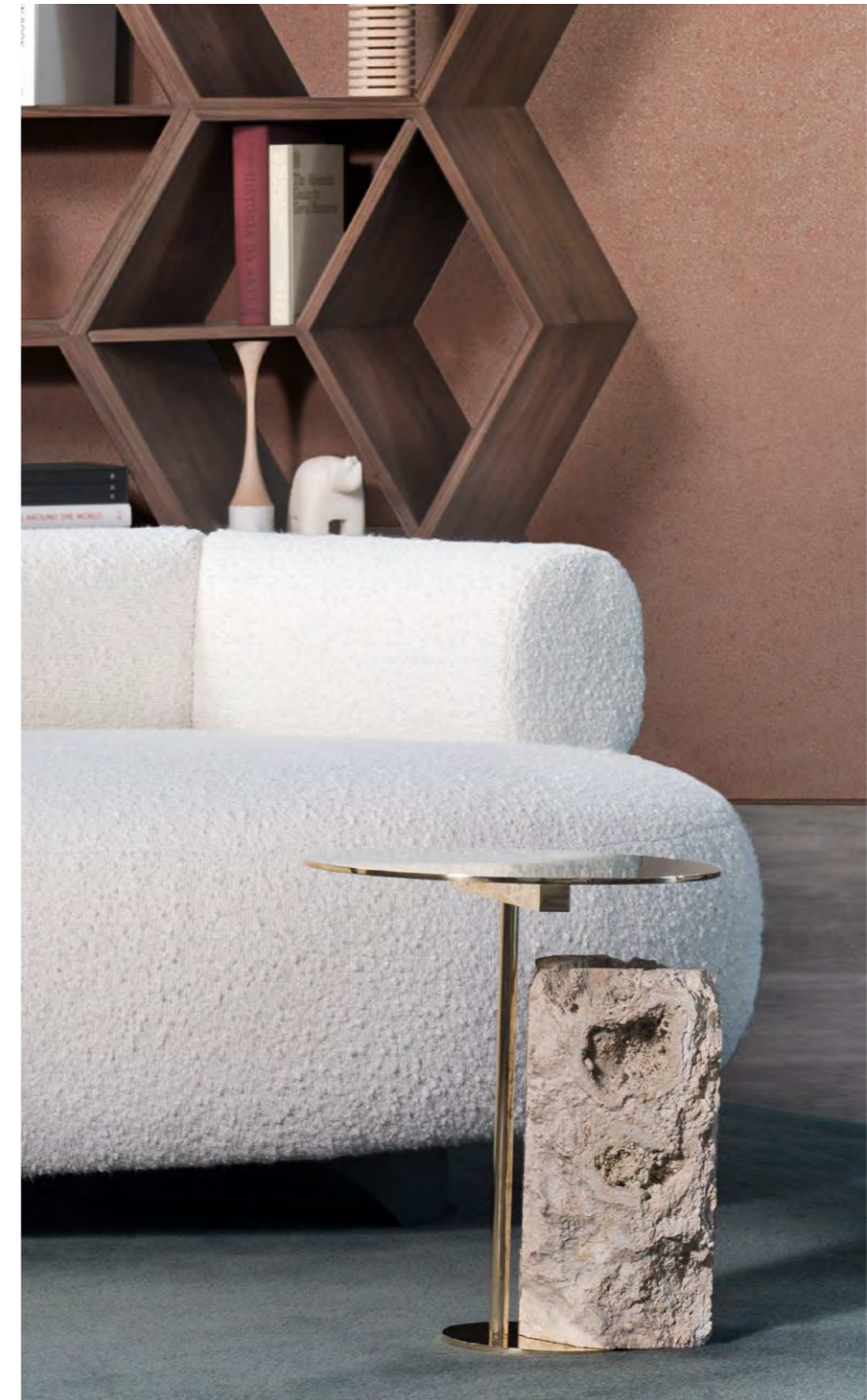

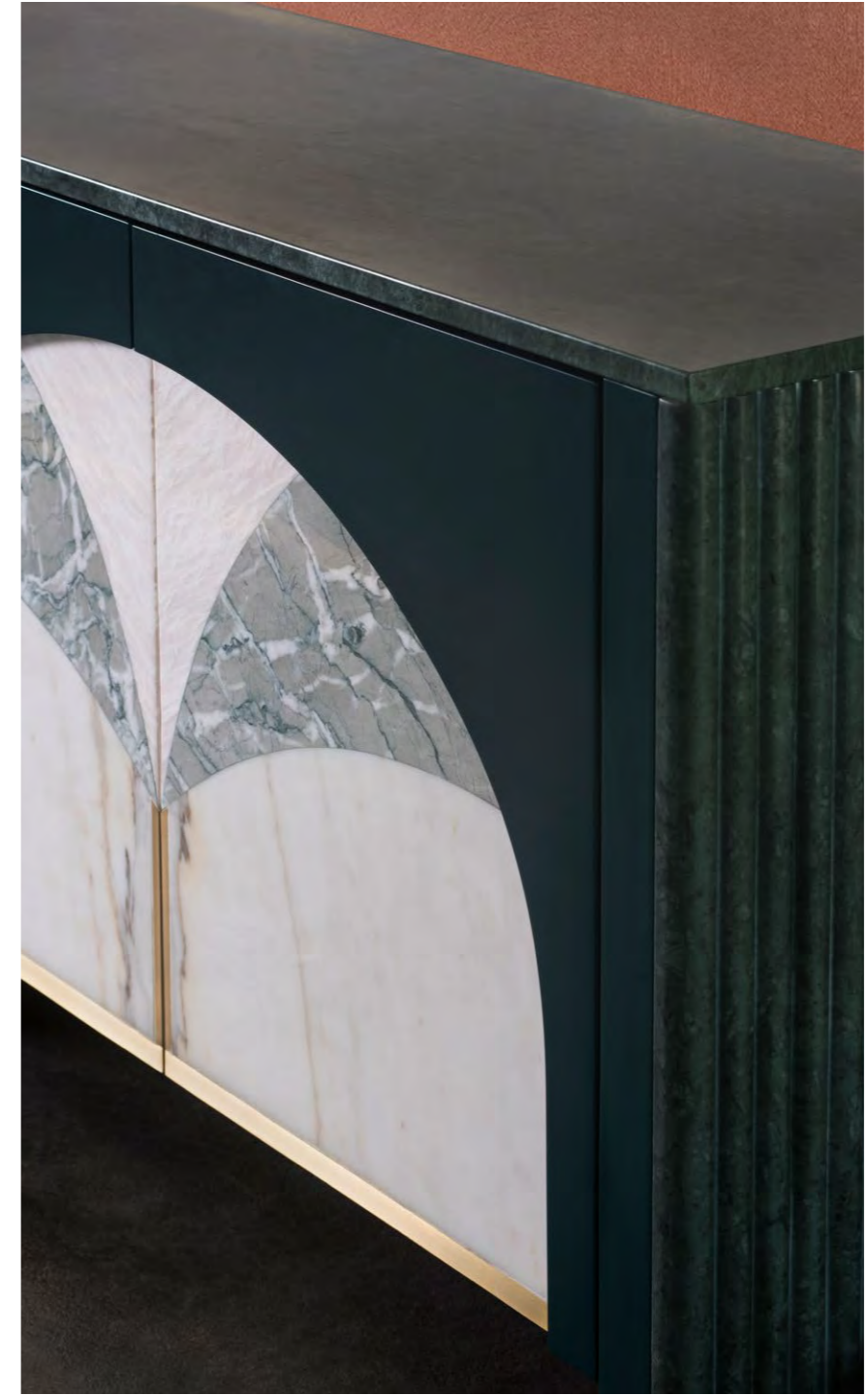







Bongó

Bar cabinet

G703150

Wooden bar cabinet with round structure lacquered in high-gloss champagne-coloured bronze powder. Semicircular sliding doors in polished Sahara *Noir* marble, automatically activated by touch and movement. Cabinet interiors in walnut veneer matt finish and polished Patagonia granite, backlit with LED lighting triggered on door opening. Includes glass holder, wine rack and drawers. Legs and handles in oxidised brass with a high-gloss finish. Limited edition.



Sahara Noir marble and oxidised brass





Saqris
Cabinet

G702229

Wooden cabinet with a semi-round structure lacquered in satin black. Cabinet interior with drawers, shelf compartments and LED lighting triggered on the door opening. Handles, inlay metal details and legs in brushed brass with a high-gloss finish.



Brushed brass inlay metal details

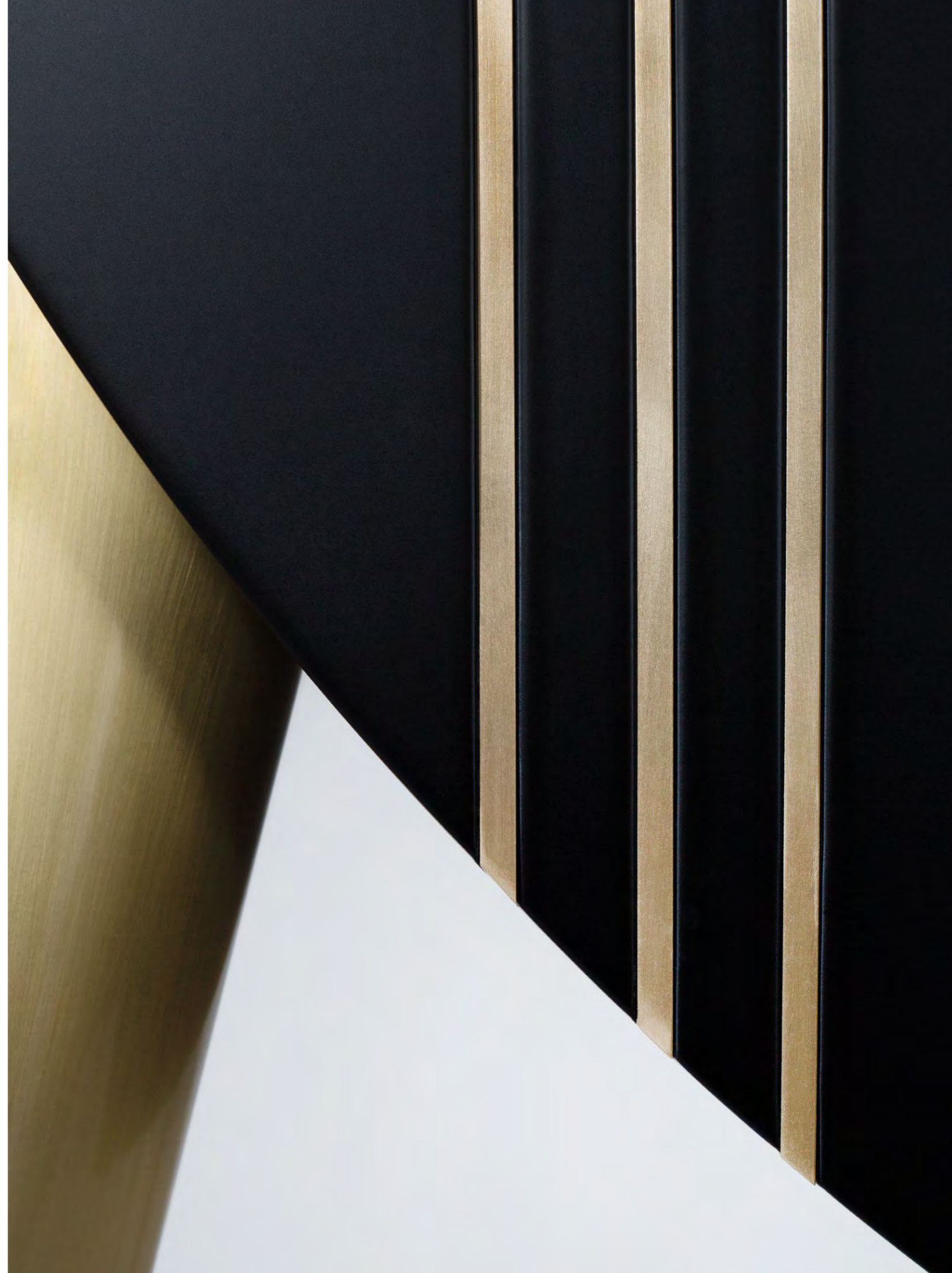



Lage
Bookcase

G703082

Metal structure bookcase lacquered in satin black. Shelves in walnut veneer with matt finish and main shelf in oxidised brass and dark oxidised brass, both with matt finish.

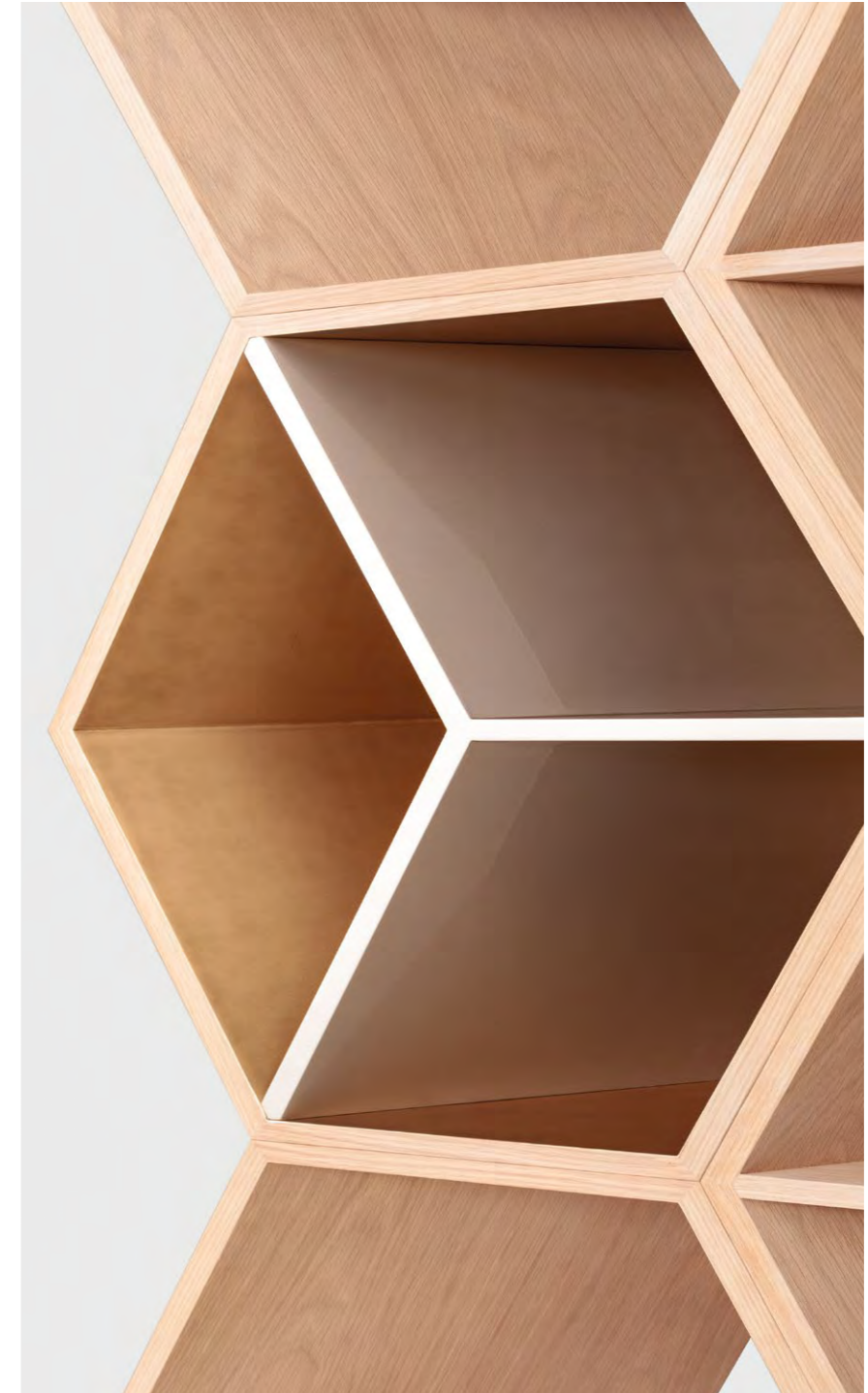

American oak veneer, champagne and gold bronze powders

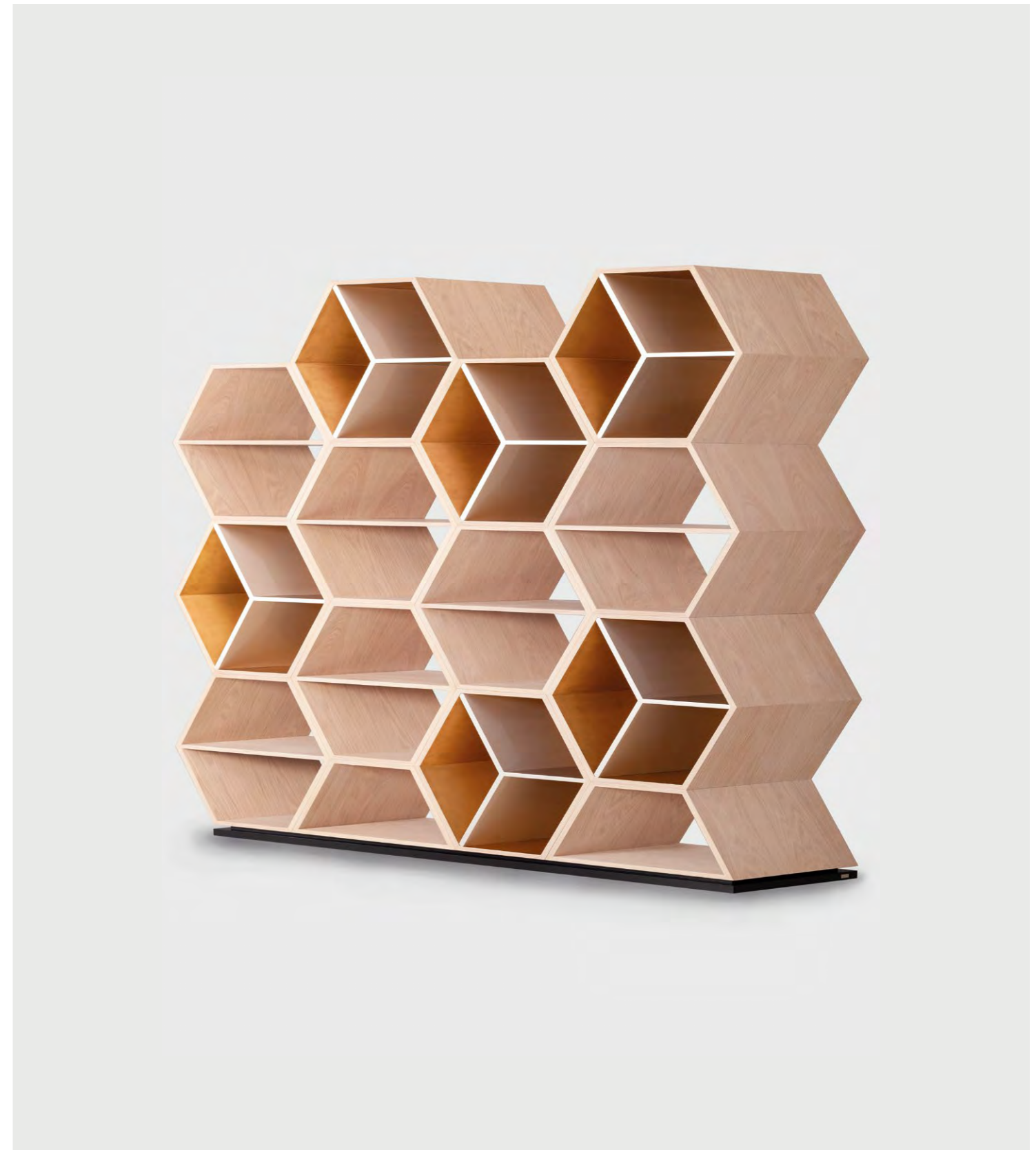

Hobart
Bookcase

G701748

Bookcase with a tridimensional hexagon pattern in open-pore American oak veneer with matt finish. Golden interior shelves lacquered in high-gloss champagne-coloured and satin gold-coloured with patina effect bronze powders. Base lacquered in satin black.



Hobart
Bookcase

G702526

Bookcase with a tridimensional hexagon pattern in walnut veneer with matt finish.
Base lacquered in high-gloss champagne-coloured bronze powder.

Sideboards

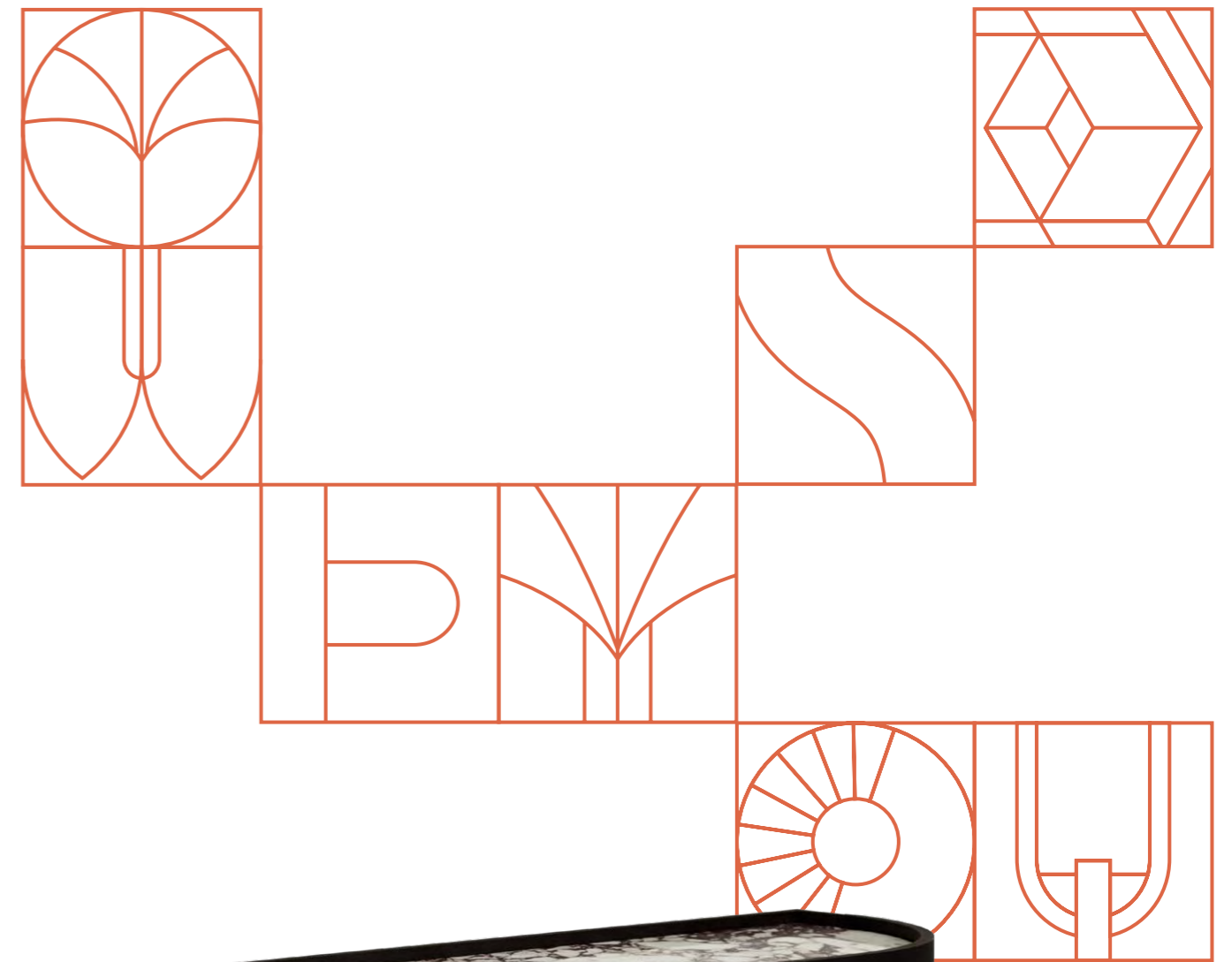



Biloba
Sideboard

G702194

Wooden sideboard lacquered in satin dark green. Top and lateral panel in polished Green Guatemala marble. Doors in three marble inlaid composition: *Rosa Egeo*, *Verde Antigua* and *Calacatta Crema*. Interior in eucalyptus *frisé* veneer, high-gloss finish, with LED lighting triggered on door opening. Inlay metal details in brushed brass with a high-gloss finish. Limited edition.





Three marble inlaid composition: *Rosa Egeo*, *Verde Antigua* and *Calacatta Crema*



Olival
Sideboard

G702419

Sideboard in American oak veneer, open-pore dark brown stained with matt finish. Top in polished *Calacatta Viola* marble. Contains drawers and shelf compartments and interior LED lighting triggered on door opening. Inlay metal details and handles in brushed brass with a high-gloss finish and metal legs lacquered in satin black.





Calacatta Viola marble



Sunshine
Sideboard

G702451

Wooden sideboard with cubic module's structure lacquered in satin black and bordeaux. Right hand door lacquered in a satin gold-coloured bronze powder with a *sfumato* effect. Ellipse module with gold leaf gilding, satin finish. Handles and leg end caps in dark oxidised brass with a high-gloss finish. Wooden legs lacquered in satin black.



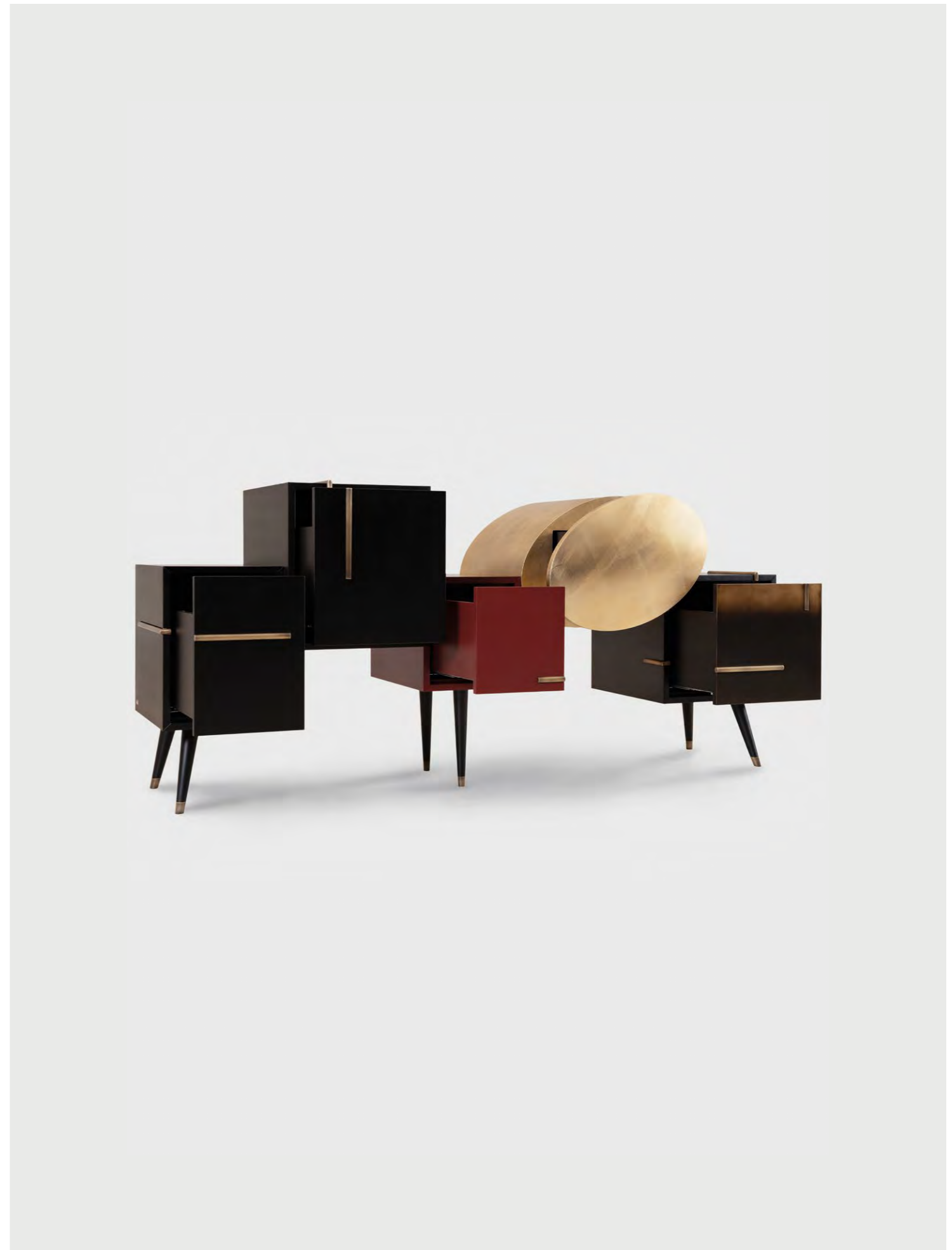

Tables & Consoles

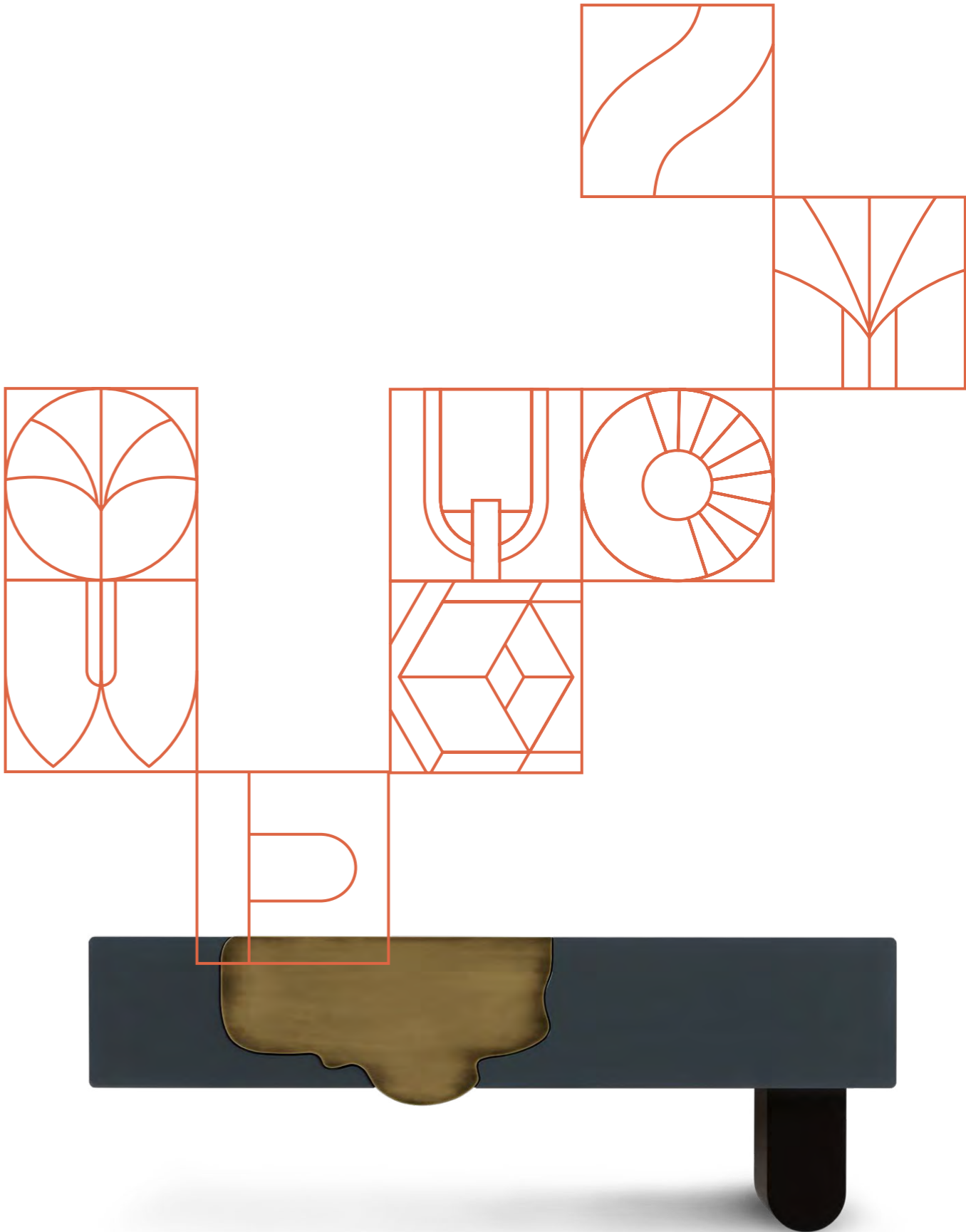



Armona

10-seater dining table

G703132

Dining table bean-shaped top with inlaid two veneers: American oak in open-pore tobacco colour stained and ash in open-pore dark brown stained, both with an eggshell finish. Table top round edge lacquered in satin black. Two semicircular bases in American oak veneer, open-pore dark brown stained with matt finish. Inlay metal details in oxidised brass with matt finish.





Olisippo

6-seater dining table

G702273

Dining table top in polished Patagonia granite backlit with LED light. Base in solid beech, dark brown stained with high-gloss finish. Inlay metal details in polished brass with a high-gloss finish. Limited edition.



Ferreirinha

6-seater dining table

G702478

Dining table top in polished *Calacatta* Black Vein marble. Base built-in American oak veneer open-pore black stained with matt finish, and upholstered in dark red high standard Italian leather. Tubular metal legs lacquered in satin light gold bronze powder with a patina effect.





Calacatta Black Vein marble



Calacatta Bianco marble and an inlay leather detail



Ferreirinha

6-seater dining table

G702291

Dining table top in matt *Calacatta Bianco* marble. Base built-in American oak veneer with matt finish, and upholstered in white, dyed leather embossed with a geometric pattern and metallic hand finishing. Tubular metal legs in brushed brass with a high-gloss finish.



Castelo
Console

G702277

Wooden console with main structure lacquered in satin black. Table top in polished Sahara *Noir* marble. Tubular metal base lacquered in high-gloss champagne-coloured bronze powder.



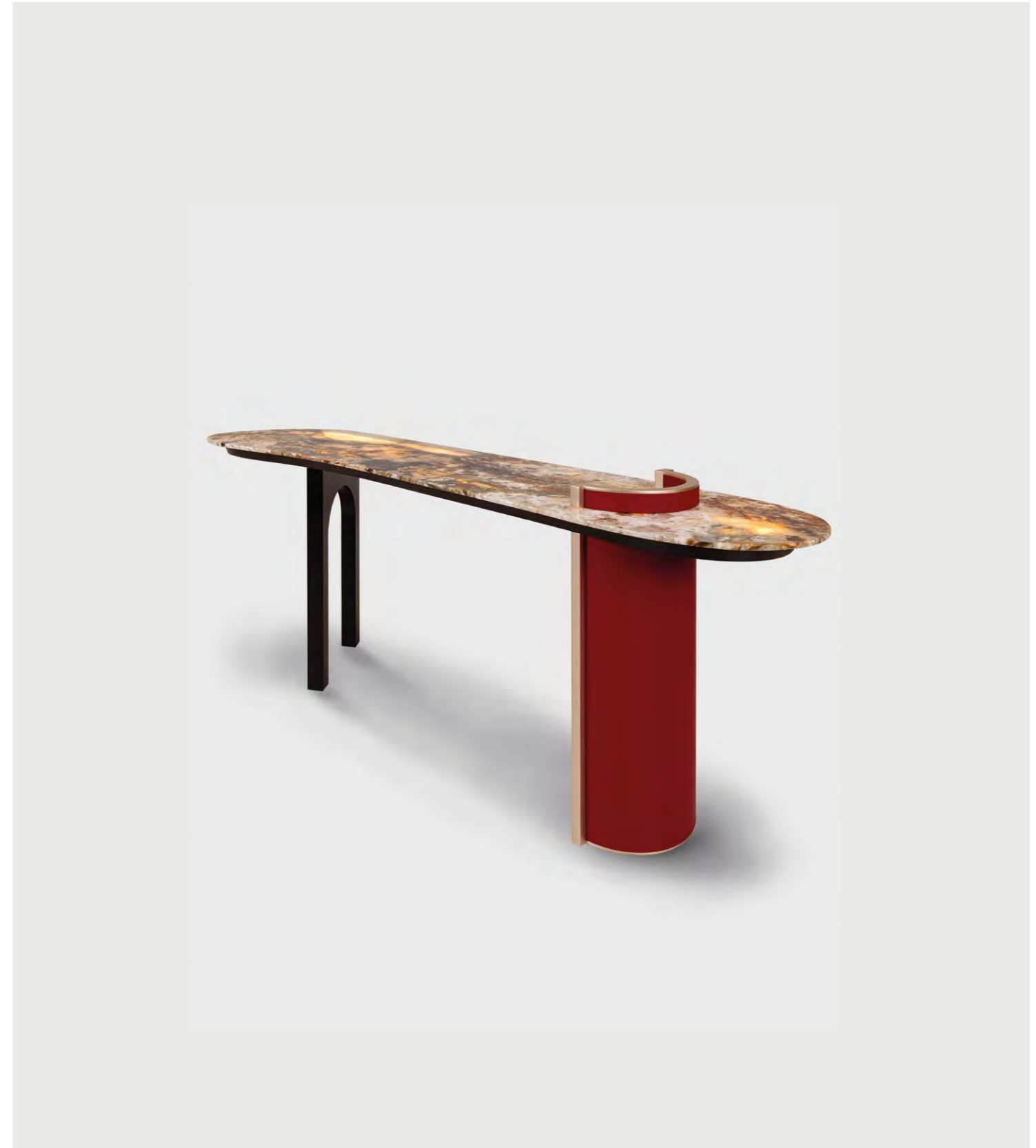
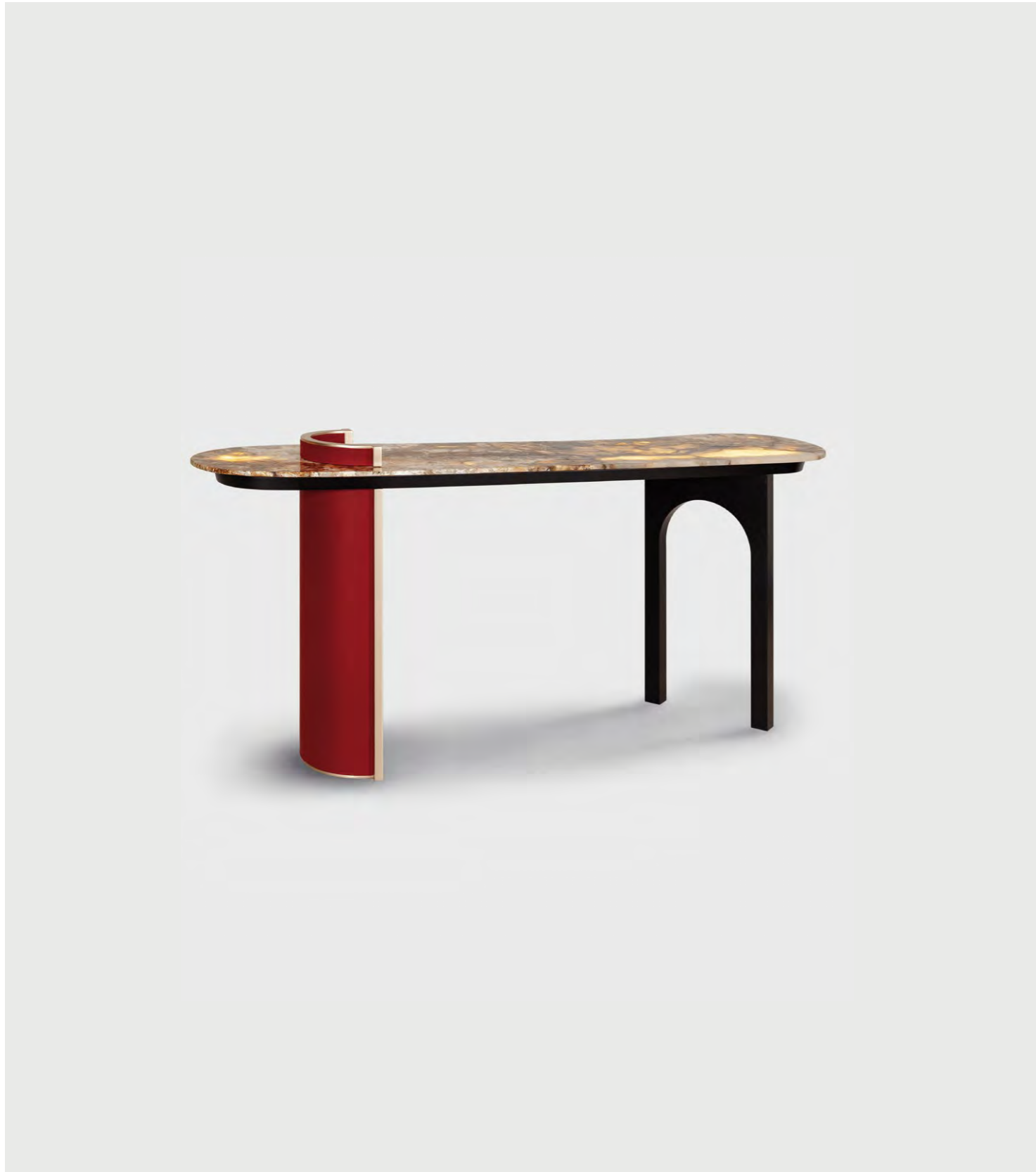

Chiado

Console

G702343

Wooden console with main structure lacquered in satin black. Table top in polished Patagonia granite backlit with LED light. Semicircular wooden base upholstered in dark red premium Italian leather, with top border detail in high-gloss champagne-coloured bronze powder.





Menir
Console

G702421

Console main structure in American oak veneer, open-pore black stained matt finish with a marble detail in polished *Calacatta Black Vein*. Wooden faceted legs lacquered in satin black and high-gloss champagne-coloured bronze powder.

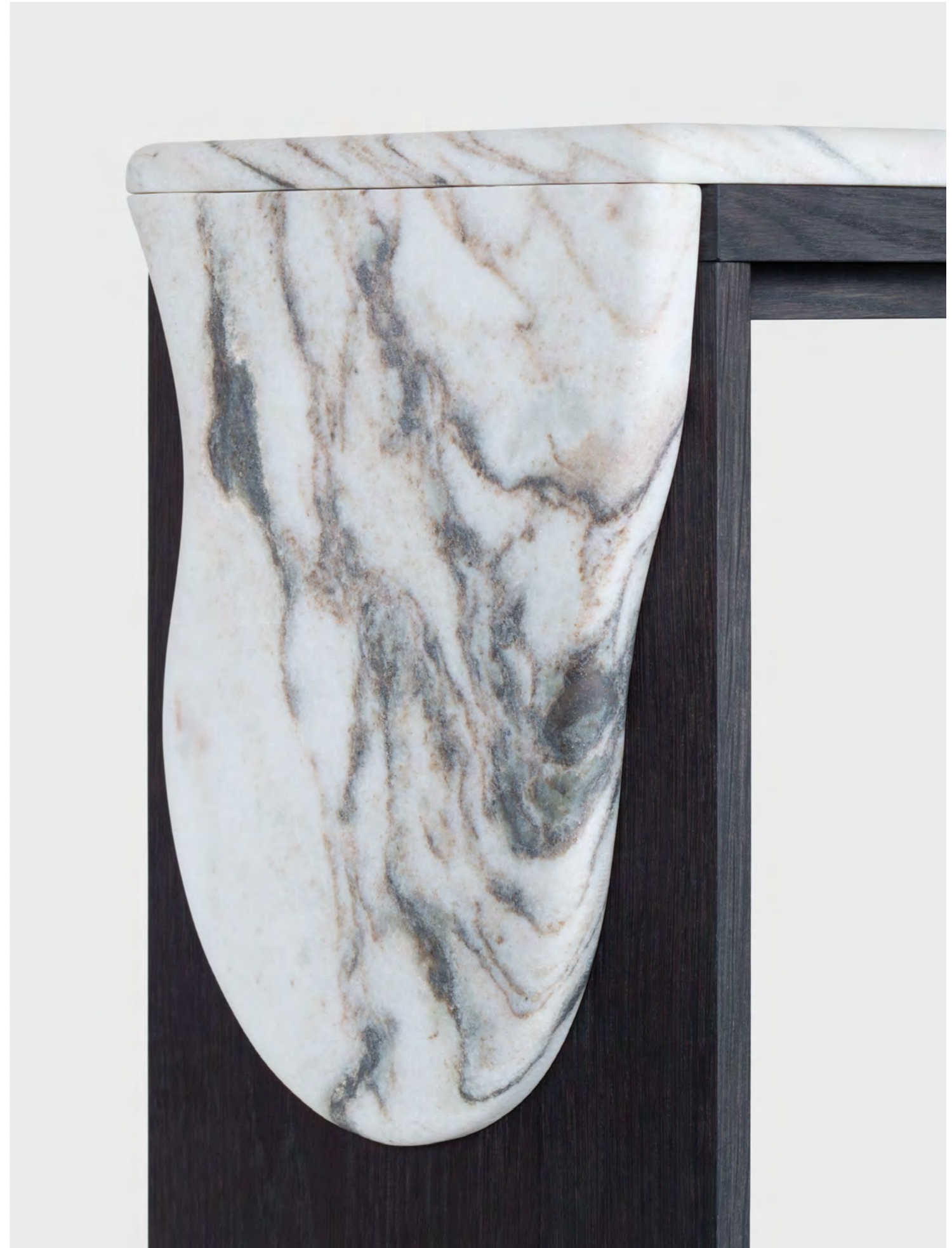



Alma
Console

G702485

Wooden console lacquered in high-gloss dark blue-grey with two drawer compartments. Front drawer panel in dark oxidised brass with a high-gloss finish. Wooden leg lacquered in satin black.



Armona
Desk

G703031

Desk with top in walnut veneer, matt finish and inlay details in dark oxidised brass with a high-gloss finish and polished Shadow onyx. Wooden legs lacquered in high-gloss champagne-coloured bronze powder. With USB port and built-in cable management.

Low tables





Bordeira

Coffee table

G703117

Coffee table with top in American oak veneer, open-pore black stained with matt finish and an inlay detail in polished Shadow onyx. Cylindrical legs in solid beech, black stained with matt finish.

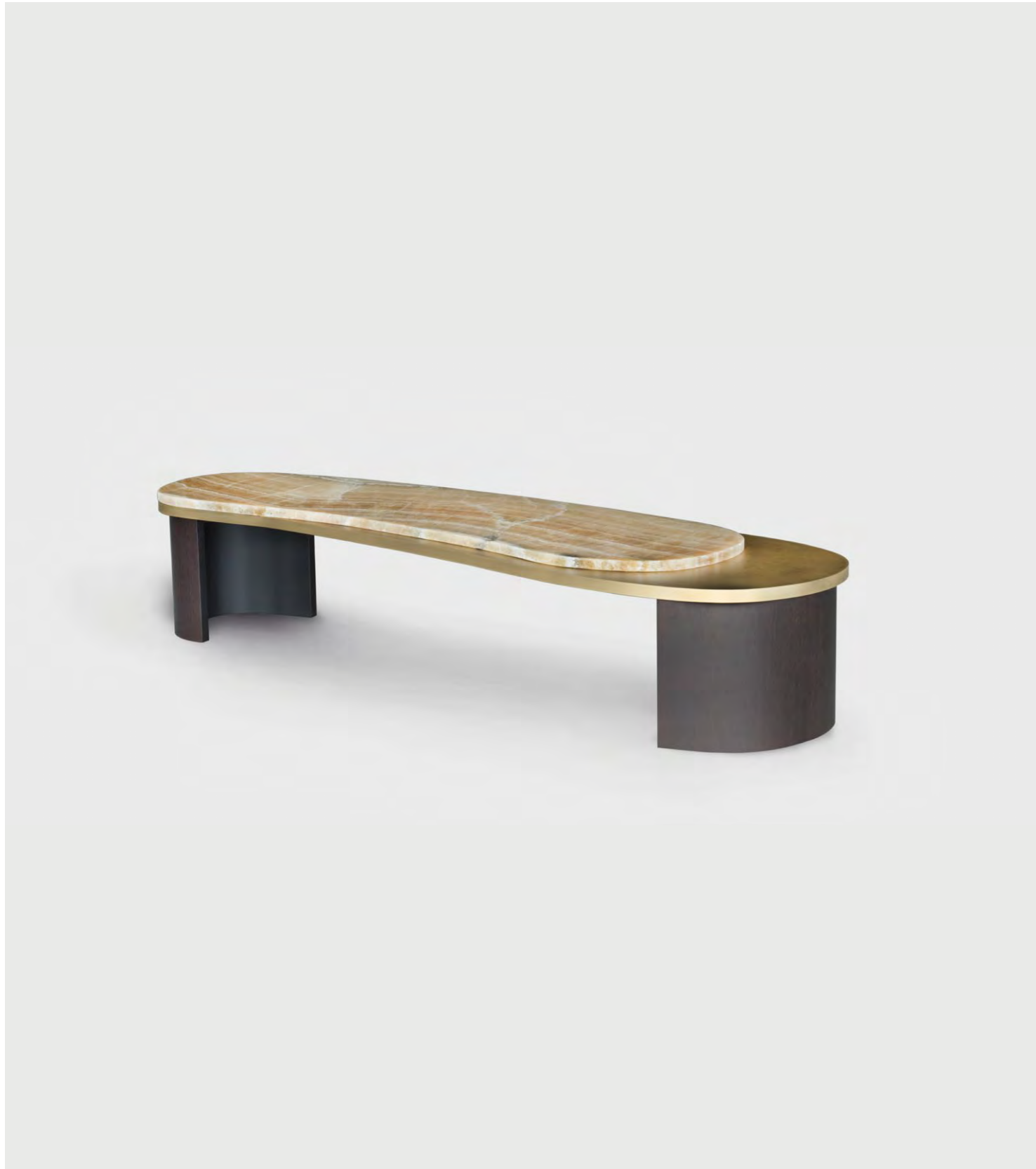

Armona
Coffee table

G703133

Wooden coffee table with top in dark oxidised brass with matt finish and polished Shadow onyx. Semicircular legs in American oak veneer open-pore black stained with matt finish.

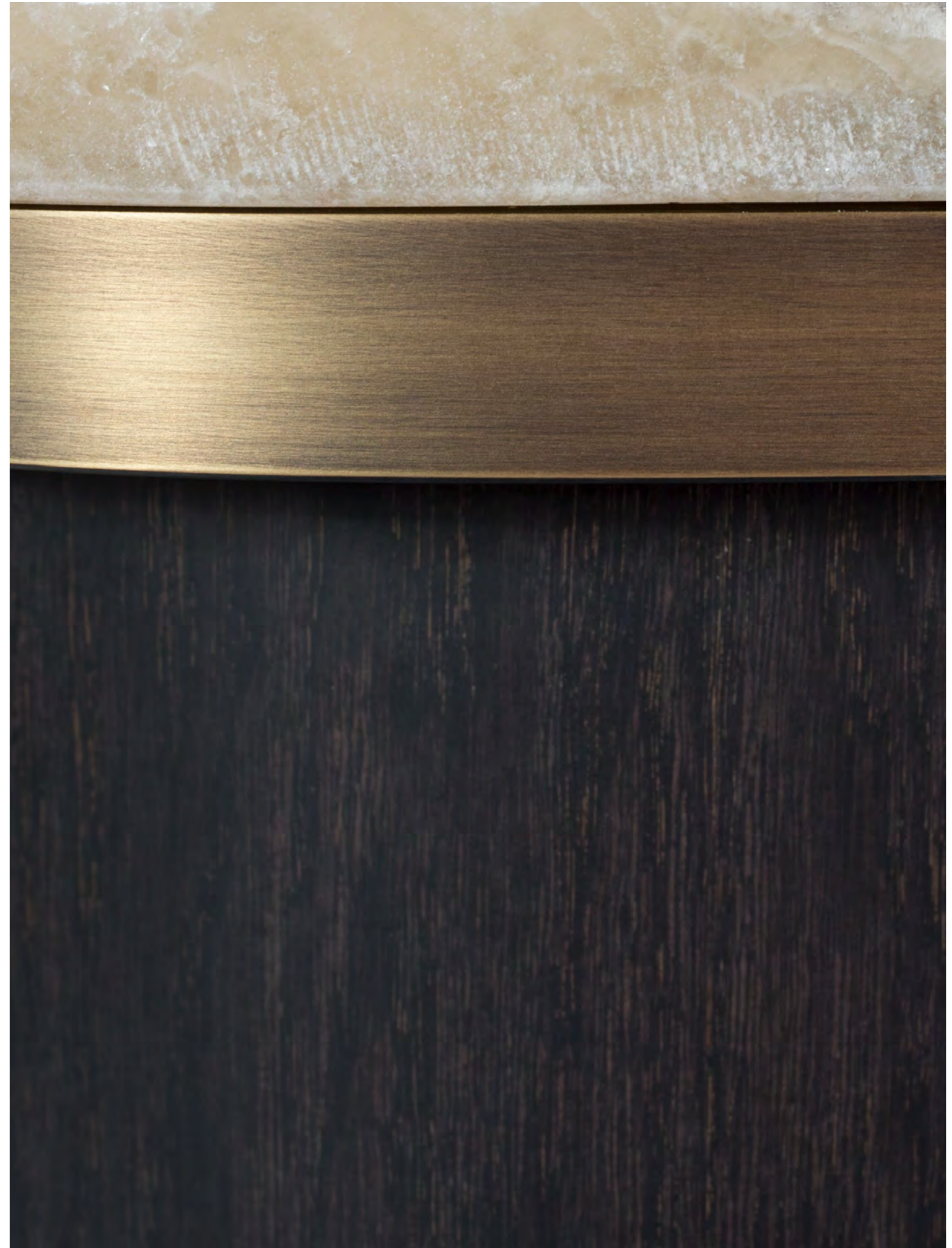



Shadow onyx and dark oxidised brass



Sistelo

Coffee table

G702470

Coffee table with top in oak root veneer with satin finish. Wooden base lacquered in satin black and high-gloss champagne-coloured bronze powder. Inlay metal details in brushed brass with a high-gloss finish.

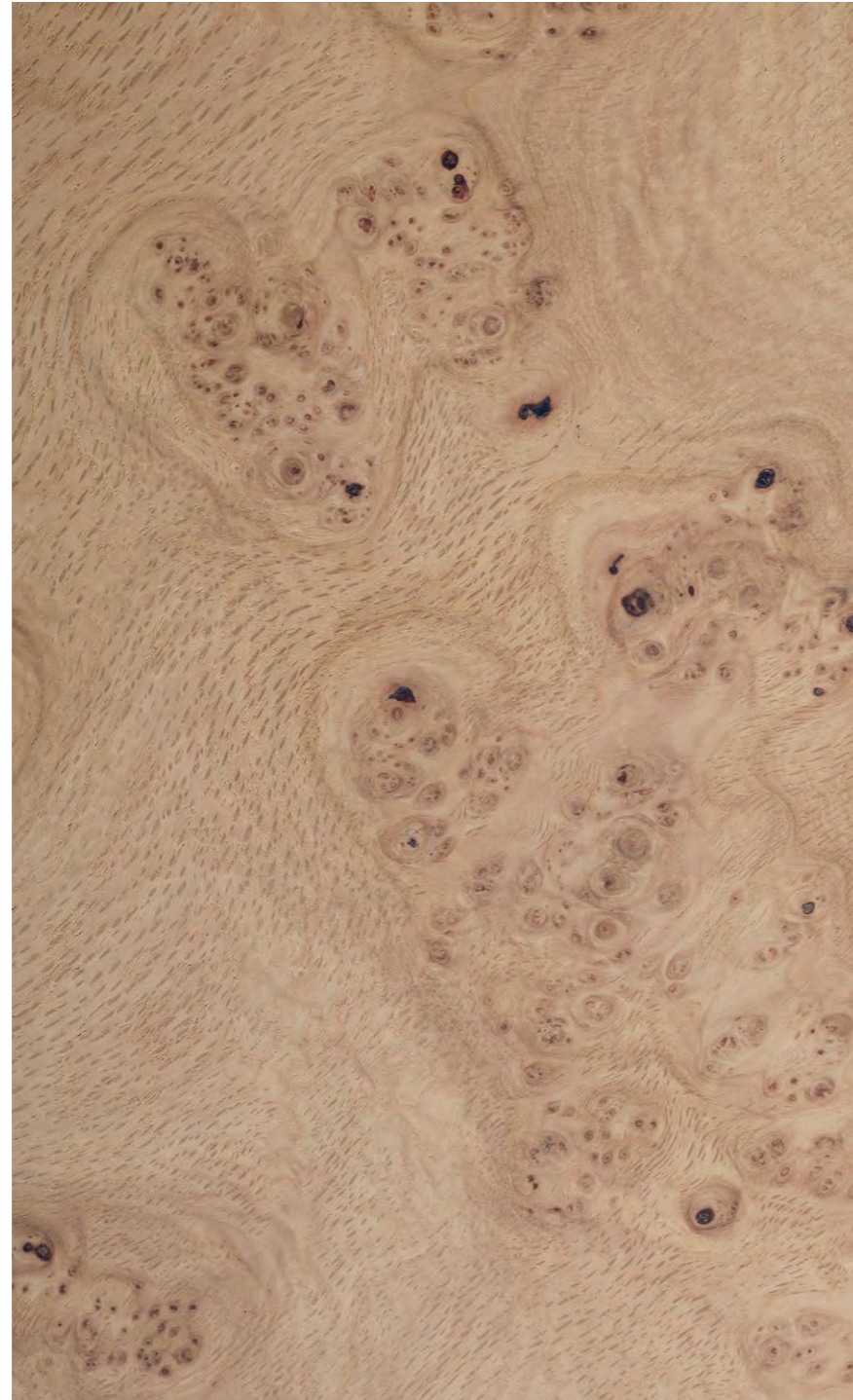

Oak root veneer





Aire

Coffee table

G703096

Coffee table top in matt *Bardiglio* marble with a split face effect on the edge and an inlay metal detail in oxidised brass with a high-gloss finish. Metal structure base lacquered in satin black.





Bardiglio marble and oxidised brass



Nero Marquina marble and dark oxidised brass



Aire

Coffee table

G702420

Coffee table top in matt *Nero Marquina* marble with a split face effect on the edge and an inlay metal detail in dark oxidised brass with a high-gloss finish. Metal structure base lacquered in satin black.



**Mó**

Coffee table

G702467

Coffee table top in aged American oak veneer, open-pore dark brown stained matt finish, with inlaid circular metal detail in dark oxidised brass with a high-gloss finish. Wooden base lacquered in black and light gold bronze powder with a patina effect, both with satin finish.





Infinity

Coffee table

909147

Coffee table with petal-shape top in bush hammered *Calacatta Bianco* marble.
Base structure in ultra clear tempered glass with polished stainless steel hardware.



Dornes
Side table

G703094

Side table in oak root veneer with satin finish. Leg details in oxidised brass with a high-gloss finish.

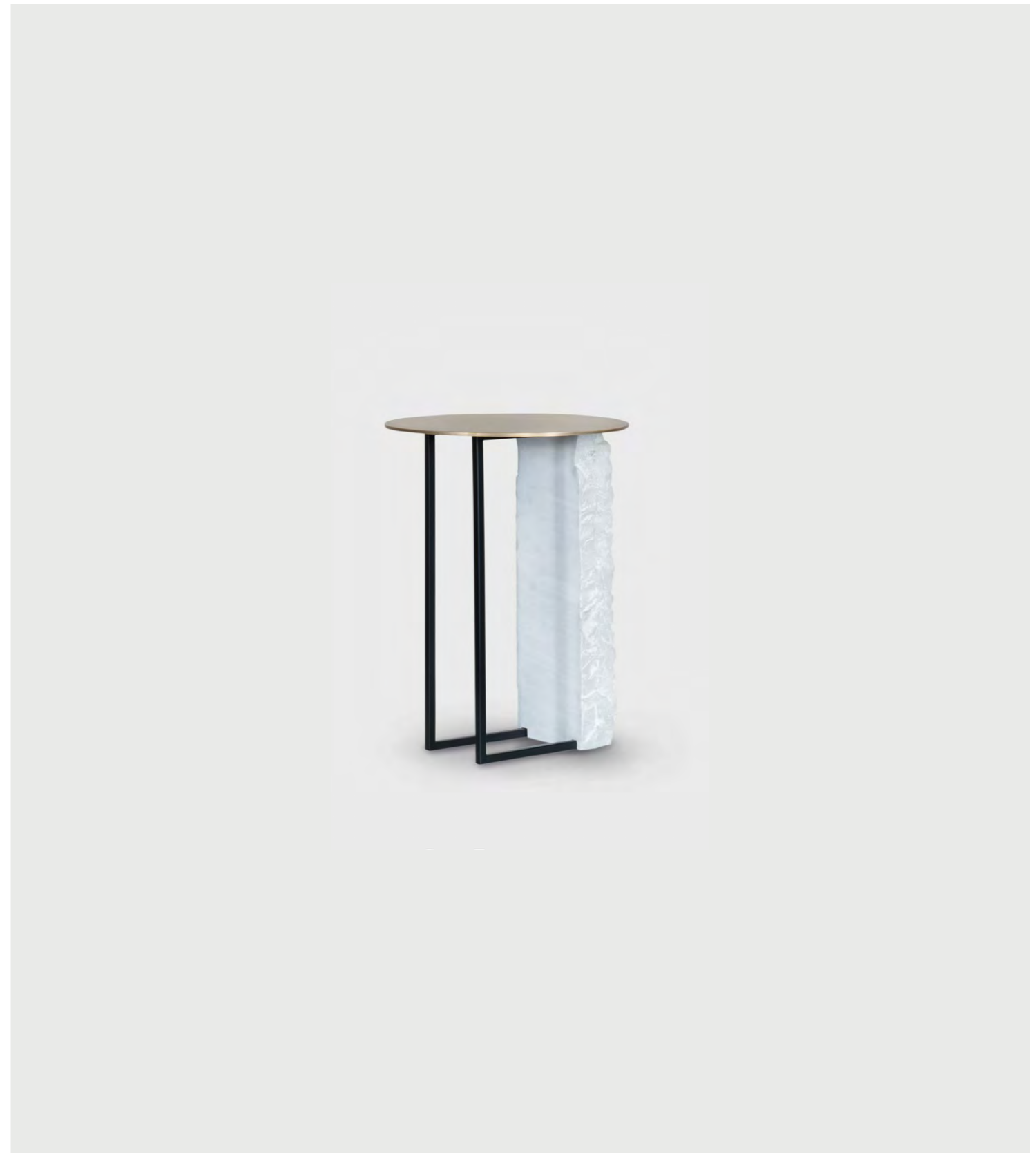

Aire

Side table

G703134

Side table top in oxidised brass with matt finish. Base in matt *Bardiglio* marble with a split face effect and metal structure lacquered in satin black.

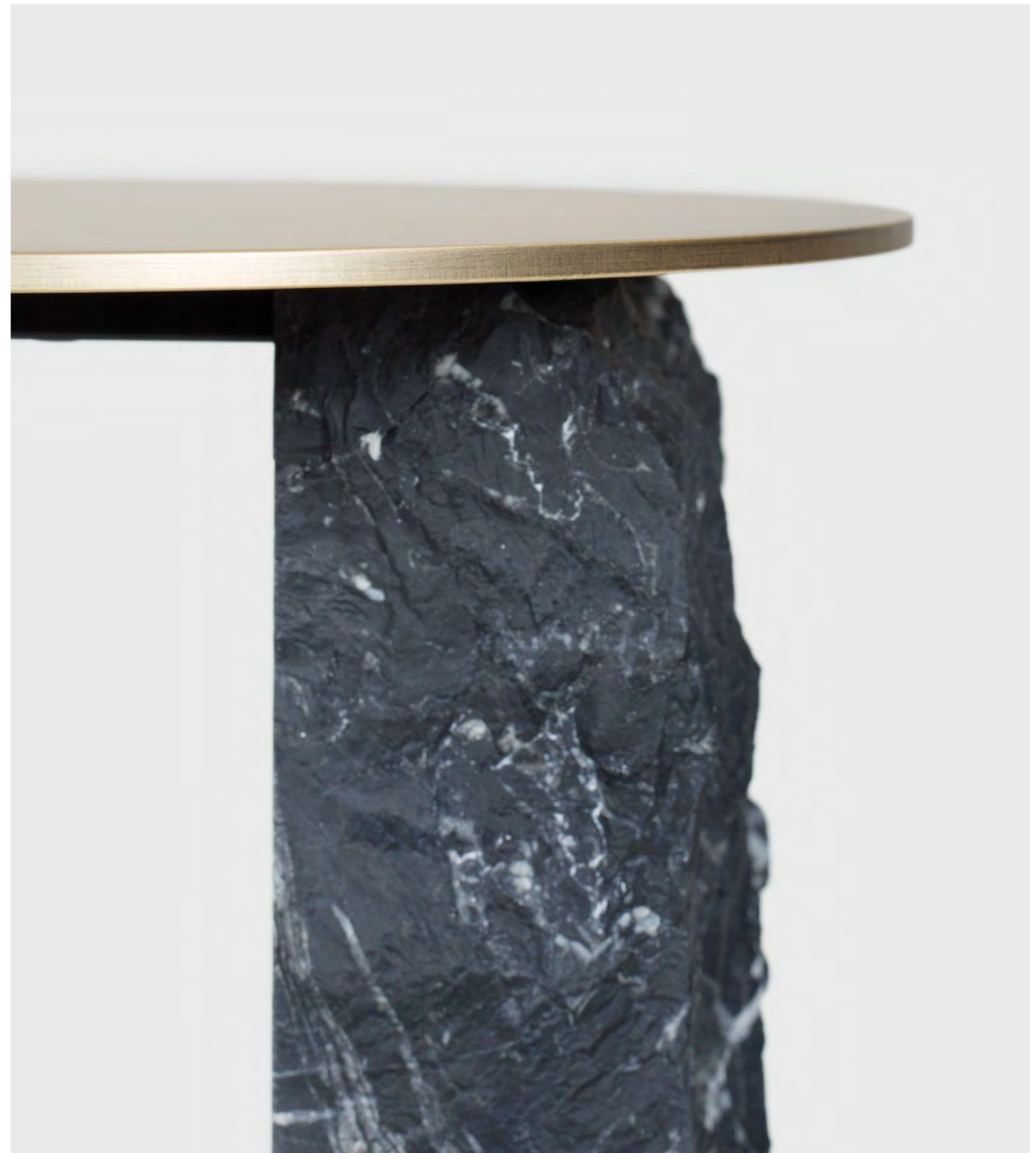

Aire

Side table

G703135

Side table top in oxidised brass with matt finish. Base in matt *Nero Marquina* marble with a split face effect and metal structure lacquered in satin black.



Pico
Side table

G703118

Side table in oxidised brass with matt finish. Base block in matt Silver *Portoro* marble with a split face effect.



Pico
Side table

G703148

Side table in oxidised brass with matt finish. Base block in matt Grey coral stone with a split face effect.



Grey coral stone



Nero Marquina marble



Pico
Side table

G703119

Side table in brushed brass with matt finish. Base block in matt Grey coral stone with a split face effect.



Pico
Side table

G703149

Side table in brushed brass with matt finish. Base block in matt Nero Marquina marble with a split face effect.



Foice

Side table

G702466

Side table in matt *Calacatta Bianco* marble. Wooden semicircular leg lacquered in satin black and metal hardware in dark oxidised brass with a high-gloss finish.



Raw
Side table

G702468

Metal side table outer shell in brushed brass with a high-gloss finish and inner shell lacquered in satin black. Base block in polished *Sahara Noir* marble.



Seating

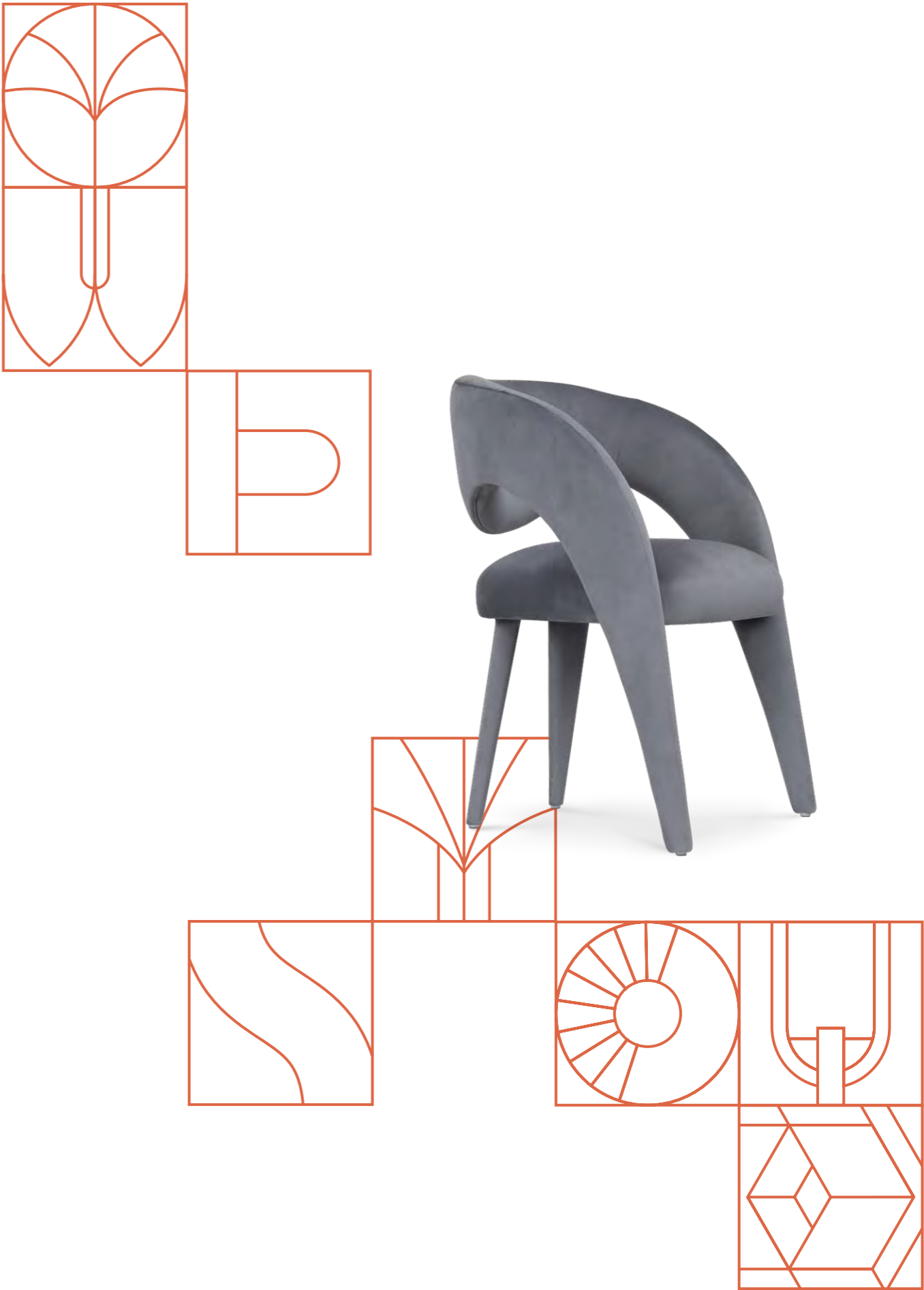



Eleanor

Chair with armrests

G702486

Wooden chair outer shell upholstered in jacquard velvet with a black *pied de poule* pattern and inner shell in a beige woven textured fabric. Legs in solid beech and lacquered in satin black.



De Castro
Chair

909718

Wooden chair upholstered in ruby-pink cotton velvet with a vertical quilting effect on the back. Semicircular backrest with an inset fillet of ebony veneer, high-gloss finish. Legs in solid beech, dark brown stained with a satin finish.



**Laurence**

Chair with armrests

G702247

Wooden chair with armrests fully upholstered in yellow cotton velvet.



Laurence

Chair with armrests

G702298

Wooden chair with armrests fully upholstered in grey technical fabric.



Laurence

Chair with armrests

G702978

Wooden chair with armrests fully upholstered in blue high standard Italian leather.



Laurence
Chair with armrests

G703137

Wooden chair with armrests fully upholstered in greyish-green nubuck velvet leather.

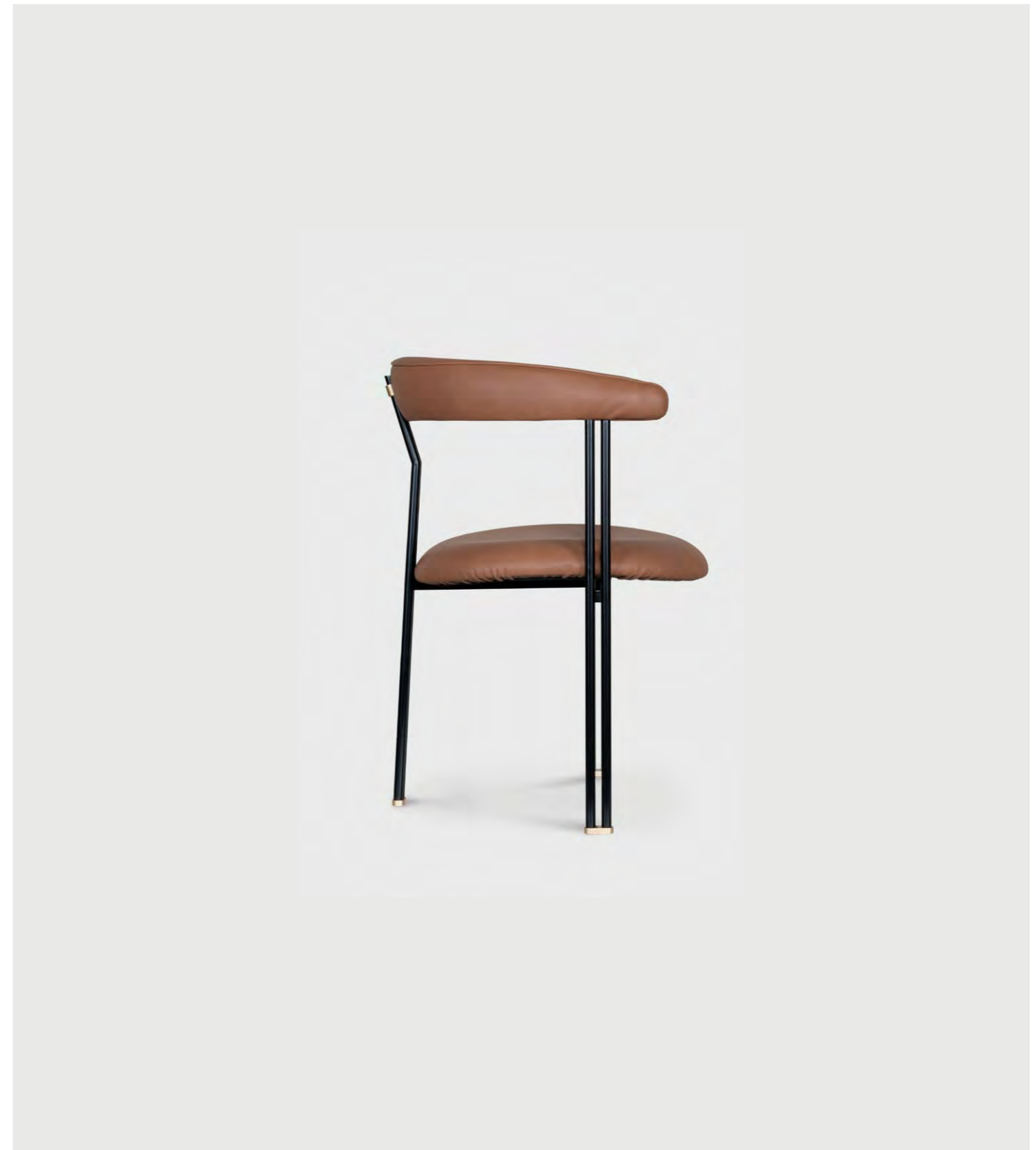

Maia

Chair with armrests

G703076

Tubular metal frame chair with armrests lacquered in satin black. Seat and backrest upholstered in caramel premium Italian leather. Metal leg end caps lacquered in high-gloss gold bronze powder.





Mary
Bar chair

G703142

Wooden bar chair upholstered in caramel high standard Italian leather. Legs in solid beech, black stained with satin finish. Metal leg end caps and footrest in brushed brass with a matt finish.





Mary
Bar chair

G702873

Wooden bar chair upholstered in red premium Italian leather. Legs in solid beech, dark brown stained with satin finish. Metal leg end caps and footrest in dark oxidised brass with a matt finish.

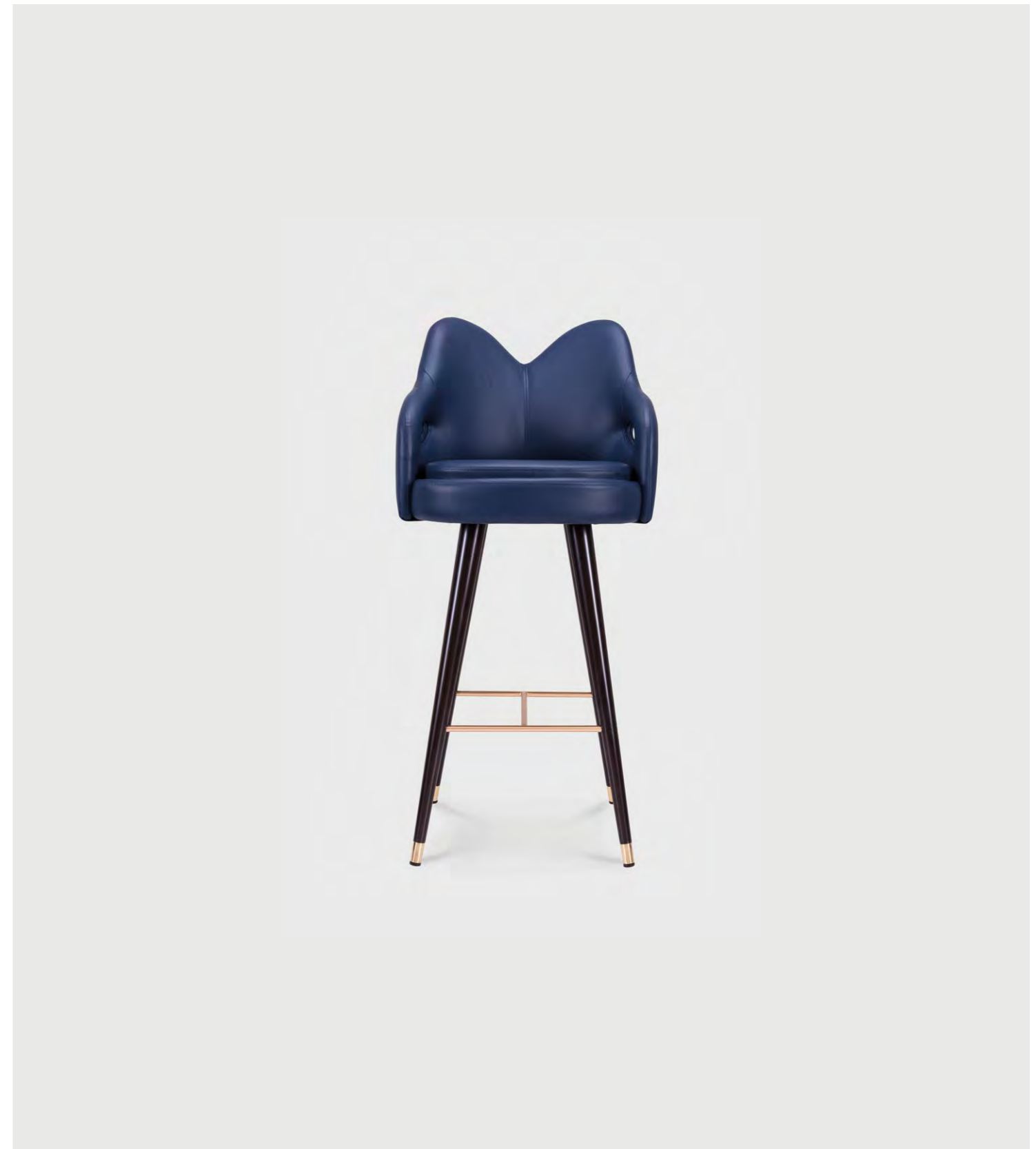
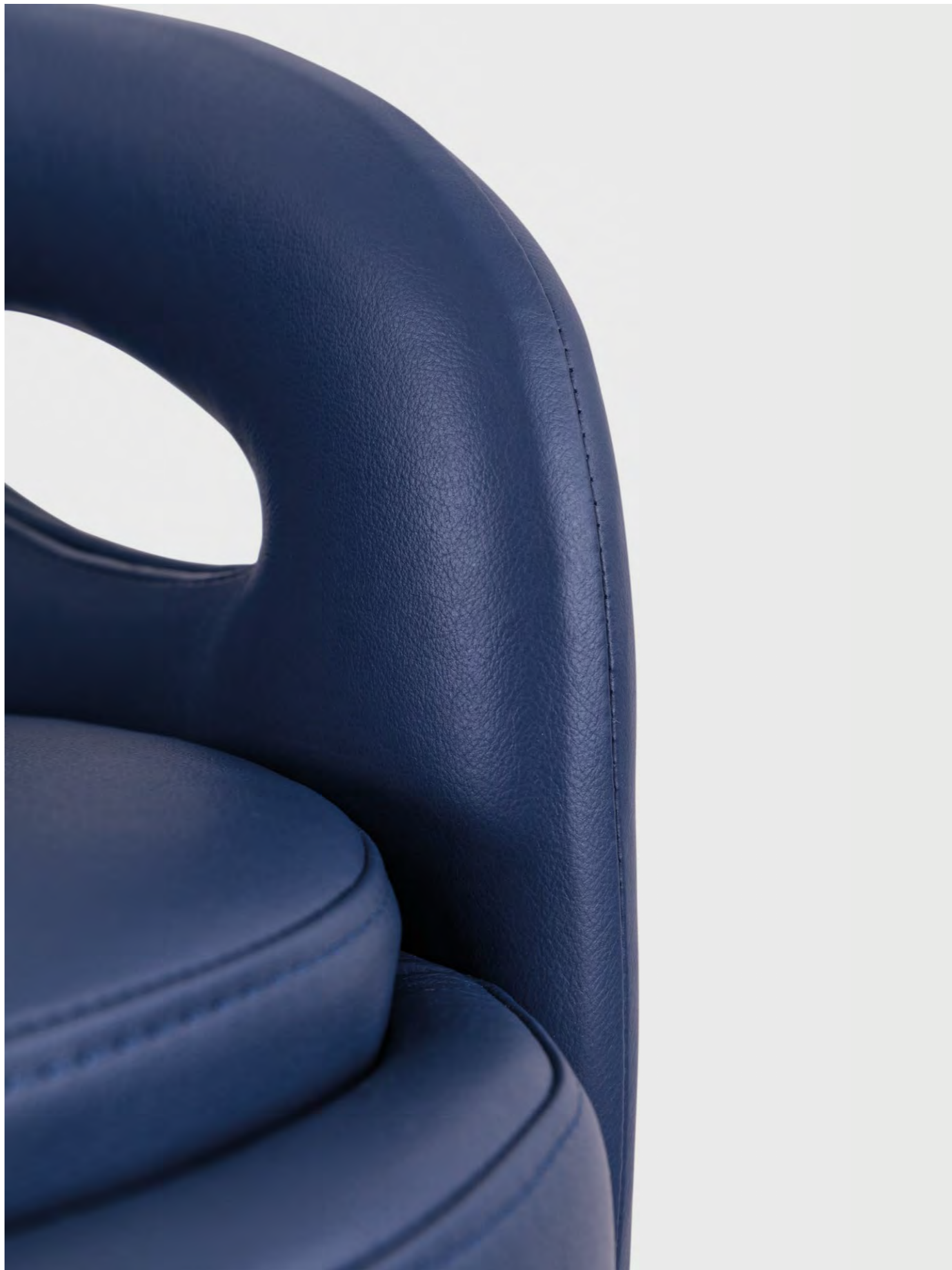

Mary
Bar chair

G702549

Wooden bar chair upholstered in navy blue high standard Italian leather. Legs in solid beech, dark brown stained with satin finish. Metal leg end caps and footrest in brushed brass with a high-gloss finish.



Galapinhos
4-seater sofa

G703101

Curved wooden sofa upholstered in caramel nubuck velvet leather. Base in American oak veneer, open-pore black stained with matt finish.





Almourol
4-seater sofa

G703102

Wooden sofa upholstered in olive-green premium Italian leather. Base in solid beech, black stained with matt finish.





Olive-green premium Italian leather upholstery





Beijinho
4-seater sofa

G703099

Wooden sofa upholstered in olive-green premium Italian leather. Base in solid beech, black stained with matt finish.





Beijinho

3-seater sofa

G702863

Wooden sofa upholstered in beige jacquard-patterned velvet. U-shape wooden frame upholstered in gold-coloured dyed leather, inserted within the armrest and base. Base in solid beech, dark brown stained with satin finish.





Beijinho

Sofa with chaise longue

G702342

Wooden sofa with chaise longue upholstered in beige jacquard-patterned velvet. U-shape wooden frame lacquered in high-gloss gold bronze powder, inserted within the armrest and base.





Beijinho

Single sofa

G702334

Wooden single sofa upholstered in beige jacquard-patterned velvet. U-shape wooden frame upholstered in gold-coloured dyed leather, inserted within the armrest and base. Base in solid beech, dark brown stained with satin finish.



Twins

4-seater sofa

G703009

Curved wooden sofa upholstered in pearl cotton-linen blend *bouclé* fabric. Wooden base lacquered in brown-gold bronze powder with a patina effect, eggshell finish.

**Twins**

3-seater sofa

G702404

Curved wooden sofa upholstered in grey cotton-linen blend bouclé fabric. Wooden base lacquered in black with a satin finish.



**Twins**

3-seater sofa

G702711

Curved wooden sofa upholstered in light grey nubuck velvet leather. Wooden base lacquered in satin grey.



Light grey nubuck velvet leather upholstery



Blue-grey nubuck velvet leather upholstery



Twins

Chaise longue

G702734

Curved wooden chaise longue upholstered in blue-grey nubuck velvet leather.
Wooden base lacquered in satin black.



Twins

Chaise longue

G703108

Wooden curved chaise longue upholstered in white cotton-linen blend *bouclé* fabric.
Base in American oak veneer, open-pore dark brown stained with matt finish.





Minho

Chaise longue

G702482

Curved wooden chaise longue upholstered in red cotton velvet. Base structure with side table in walnut veneer with matt finish.



Mel

Armchair

G702710

Wooden armchair with semicircular structure upholstered in beige jacquard velvet with a leaf pattern. Seat cushion with a blind tufting effect and rolled armrest, both upholstered in pearl cotton-linen blend *bouclé* fabric. Metal armrest support in brushed brass with matt finish.





Cotton-linen blend *bouclé* fabric in a blind tufting effect upholstery



Barão
Armchair

G703080

Wooden armchair upholstered in dark green premium Italian leather with visible contrast stitching. Seat and backrest cushions with blind tufting effect upholstered in light grey nubuck velvet leather. Legs in solid beech, dark brown stained with matt finish.







Barão
Armchair

G703175

Wooden armchair upholstered in dark green premium Italian leather with visible contrast stitching. Seat and backrest cushions with blind tufting effect upholstered in caramel nubuck velvet leather. Legs in solid beech, dark brown stained with matt finish.





Capelinhos
Armchair

G702697

Wooden armchair upholstered in caramel premium Italian leather with visible contrast stitching. Wooden swivel base lacquered in satin black.





Caju
Armchair

G703020

Wooden armchair upholstered in blue high standard Italian leather. Swivel base and armrest support in oxidised brass with matt finish.

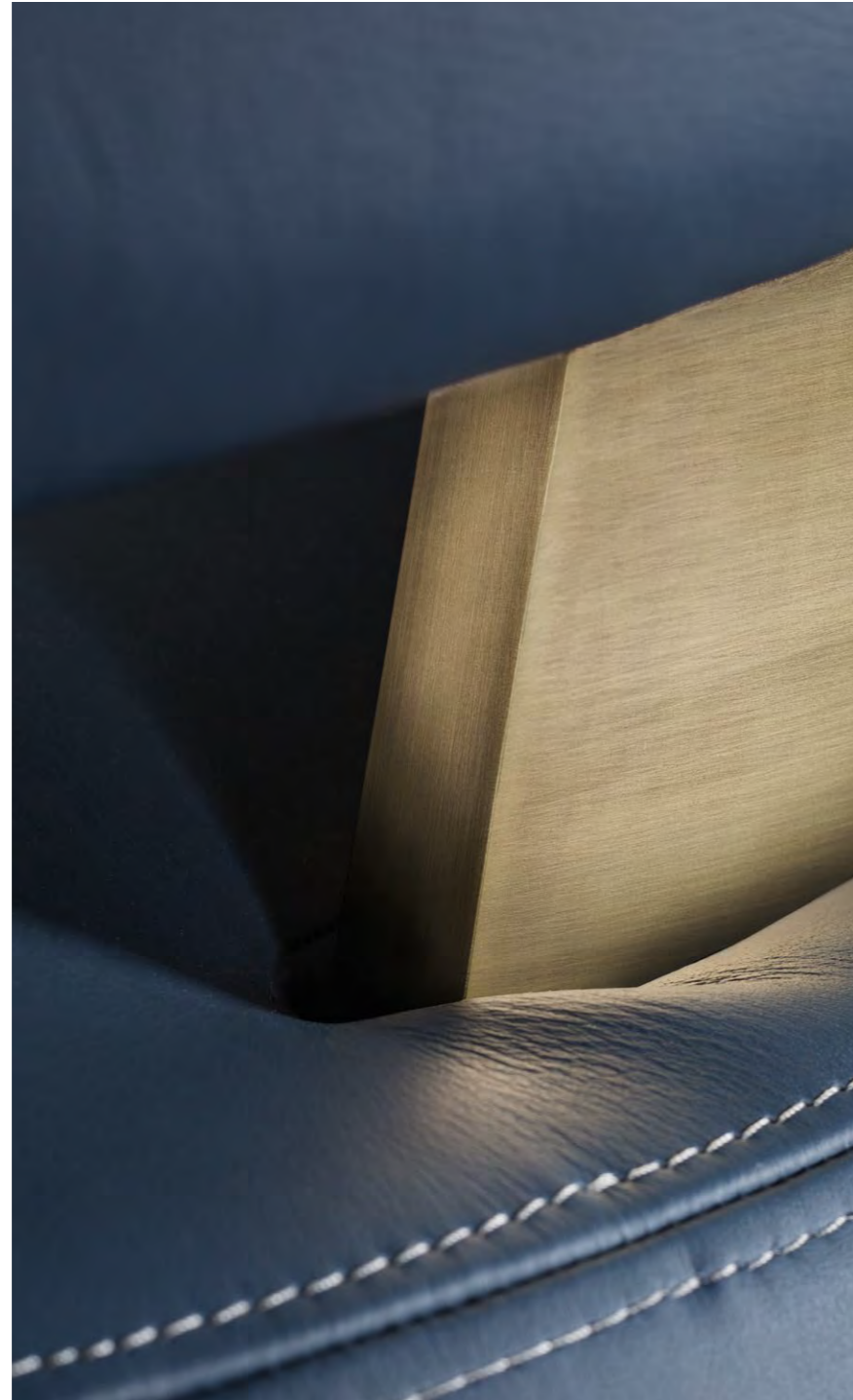

High standard Italian leather and oxidised brass



Wool *bouclé* fabric, faux fur and oxidised brass



Caju
Armchair

G703138

Wooden armchair upholstered in white wool *bouclé* fabric with armrest upholstered in white *faux* fur. Swivel base and armrest support in oxidised brass with matt finish.



Caju
Armchair

G702426

Wooden armchair upholstered in blue-green jacquard-patterned velvet. Wooden base and armrest support lacquered in champagne-coloured bronze powder with high-gloss finish.



Mons

Chaise longue

G702499

Wooden chaise longue upholstered in red high standard Italian leather. Base lacquered in high-gloss champagne-coloured bronze powder.

Lighting

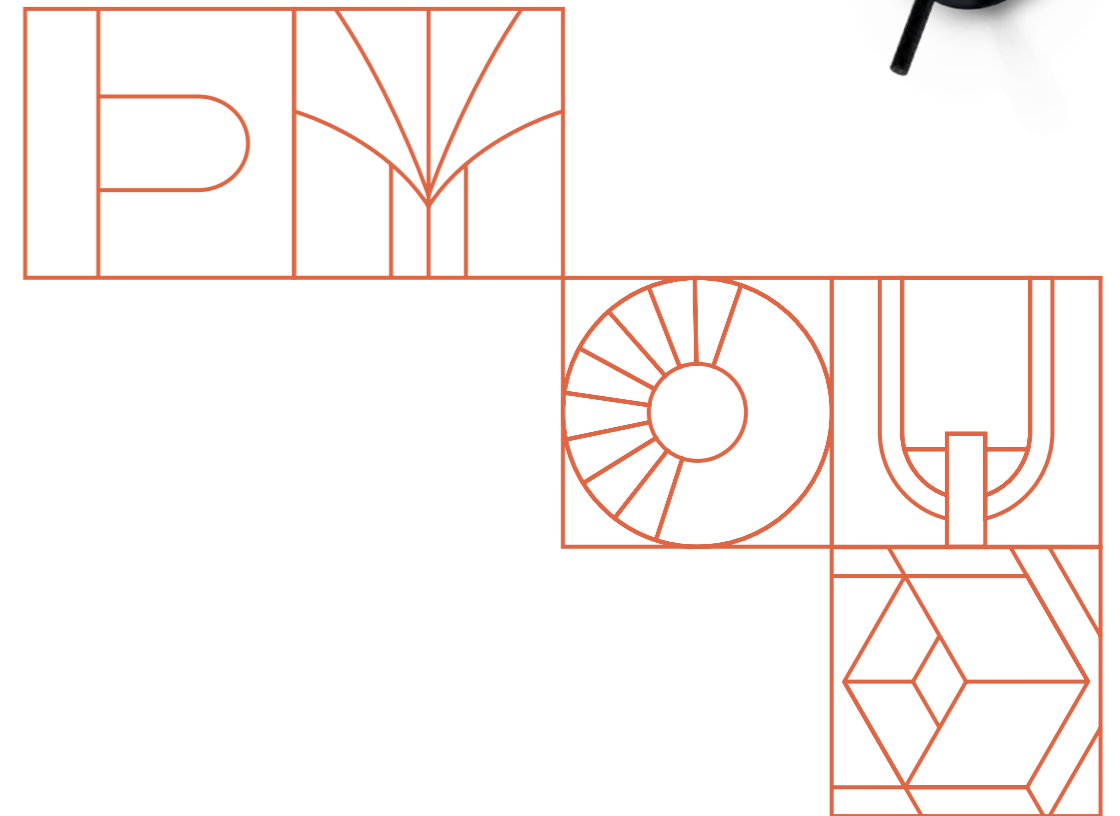
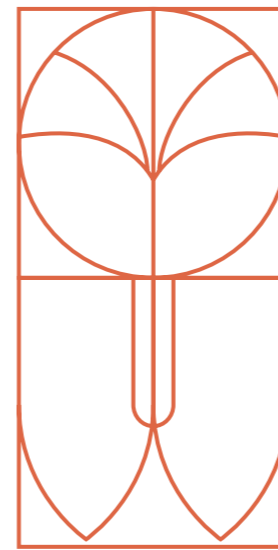



Forever
Chandelier

G702522

Chandelier with lampshade in aged American oak veneer, open-pore dark brown stained matt finish and draped aluminium chains. Canopy and light fittings in polished stainless steel. Compatible with E27 LED lamp.

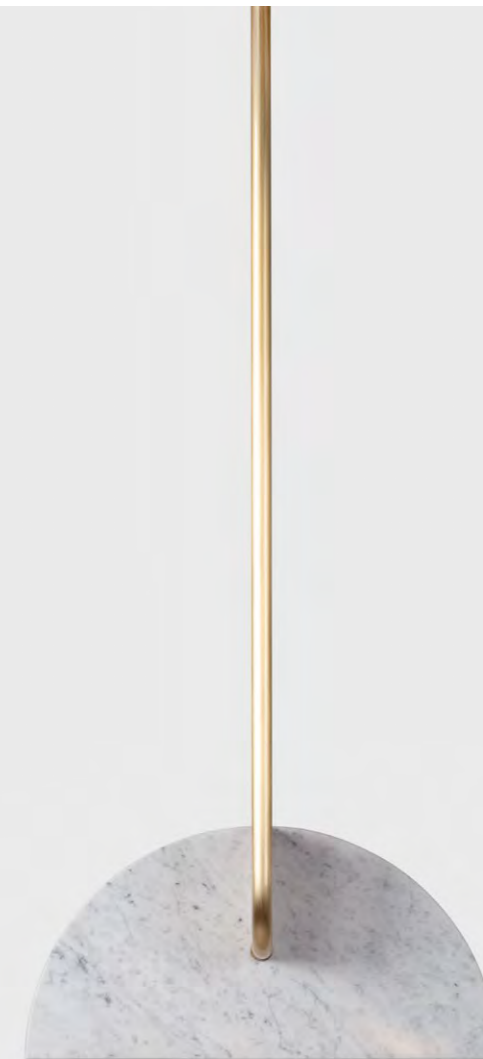

Pessoa

Suspension lamp

G702227

Suspension lamp in polished *Carrara Bianco* marble and solid American oak, open-pore with matt finish. Hanging metal tube in brushed brass with a high-gloss finish. With warm white LED strip light included.

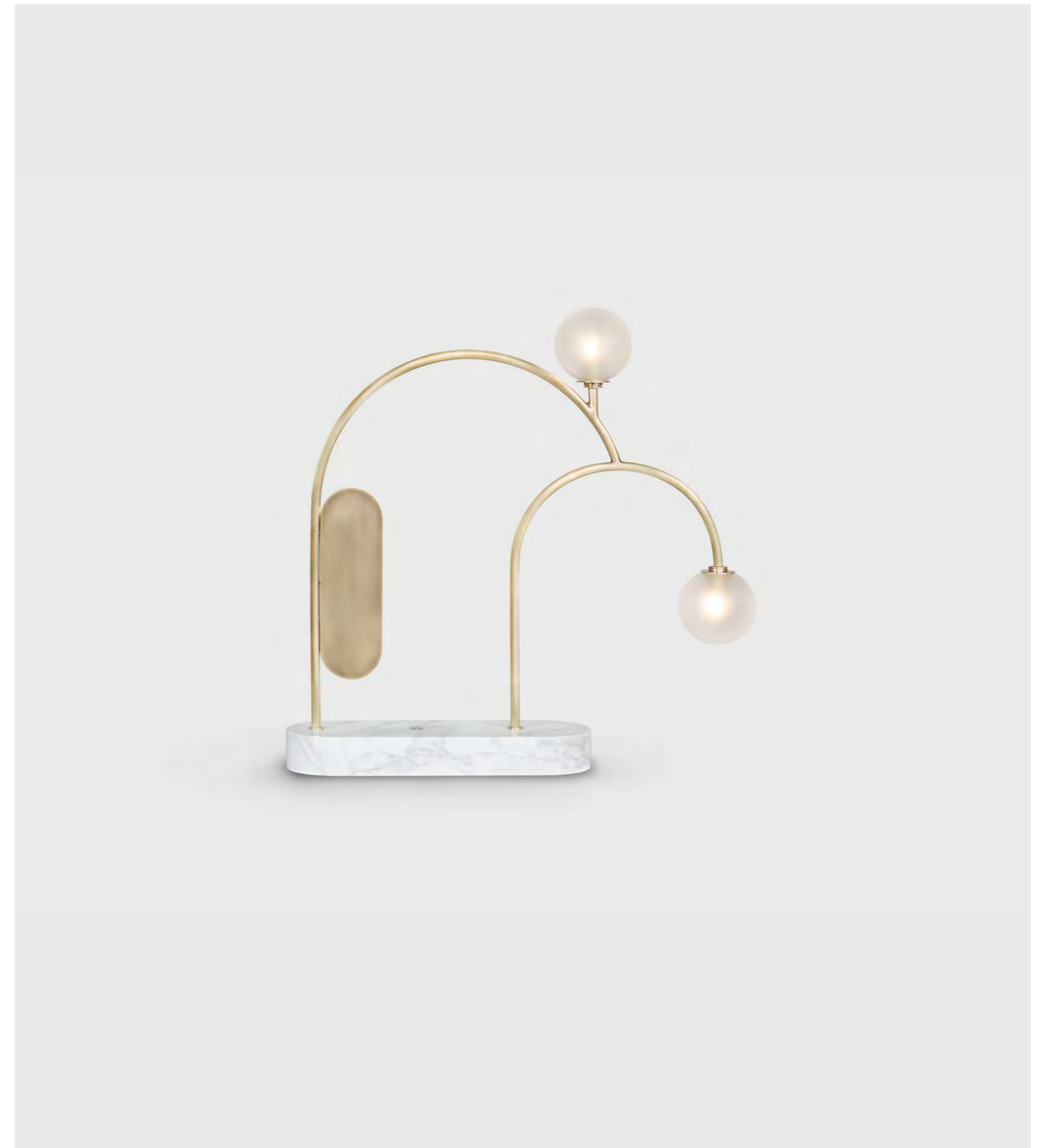

Two
Table lamp

G703145

Table lamp with frosted glass globes and tubular metal structure in brushed brass and dark oxidised brass, both with high-gloss finish. Base in polished Statuario marble. Compatible with G4 LED lamp.



Bobo
Table lamp

G702578

Metal table lamp lacquered in high-gloss champagne-coloured bronze powder.
Globe in frosted glass. With G9 LED lamp included.



Tosco
Table lamp

G702579

Metal table lamp lacquered in high-gloss champagne-coloured bronze powder.
With warm white LED strip light included.



Lima
Table lamp

G702577

Metal table lamp lacquered in high-gloss champagne-coloured bronze powder.
With warm white LED strip light included.



Opposite

Floor lamp

G702690

Metal floor lamp in brushed brass with a high-gloss finish. Pendant lampshade lacquered in satin black. Wood detail below the bridge arm in American oak veneer, open-pore black stained with matt finish. Base in polished Silver Portoro marble. With warm white LED strip light included.



Lima

Floor lamp

G702498

Floor lamp in solid beech with matt finish. Metal pendant lampshade lacquered in high-gloss champagne-coloured bronze powder. Base in matt *Calacatta Bianco* marble. Metal fittings in polished stainless steel. With warm white LED strip light included.



Sublime

Floor lamp

G701795

Arc floor lamp with telescopic stem in polished stainless steel. Pendant lampshade in black pure silk with pleated effect. Base in polished *Nero Marquina* marble. Compatible with E27 LED lamp.

264



Sublime
Floor lamp

G702296

Floor lamp with stem in polished stainless steel and lampshade in black pure silk with pleated effect. Base in polished *Nero Marquina* marble. Compatible with E27 LED lamp.

265



Sublime
Floor lamp

909108

Floor lamp with stem in polished stainless steel and lampshade in white pure silk with pleated effect. Base in polished *White Calacatta* marble. Compatible with E27 LED lamp.



Opposite
Wall lamp

G702692

Metal wall lamp lacquered in satin black. With warm white LED strip light included.



Complements





Rosim

Decorative wall piece

G702471

Decorative wall piece in brushed brass high-gloss finish and matt *Statuario* marble. Details in solid American oak, open-pore with a matt finish. With warm white LED strip light included.



Rosim

Decorative wall piece

G702520

Decorative wall piece in brushed brass high-gloss finish and matt *Statuario* marble. Details in solid American oak, open-pore with a matt finish. With warm white LED strip light included.



Flute
Mirror

G702248

Decorative wall mirror with round crystal mirrors, clear-colour, resting on top of a tubular metal structure lacquered in high-gloss gold bronze powder.



Bubbles 10

Mirror

G700705

Decorative wall mirror with wooden structure lacquered in satin white, combining assorted texture round discs: clear-colour crystal mirrors; polished *Nero Marquina* and *Statuario* marbles; and wooden discs lacquered in high-gloss silver bronze powder with textured and patina effect.



Bubbles 10

Mirror

G702491

Decorative wall mirror with wooden structure lacquered in satin white, combining assorted texture round discs: clear-colour crystal mirrors; polished *Sahara Noir* and *Statuario* marbles; and wooden discs lacquered in high-gloss silver bronze powder with textured and patina effect.

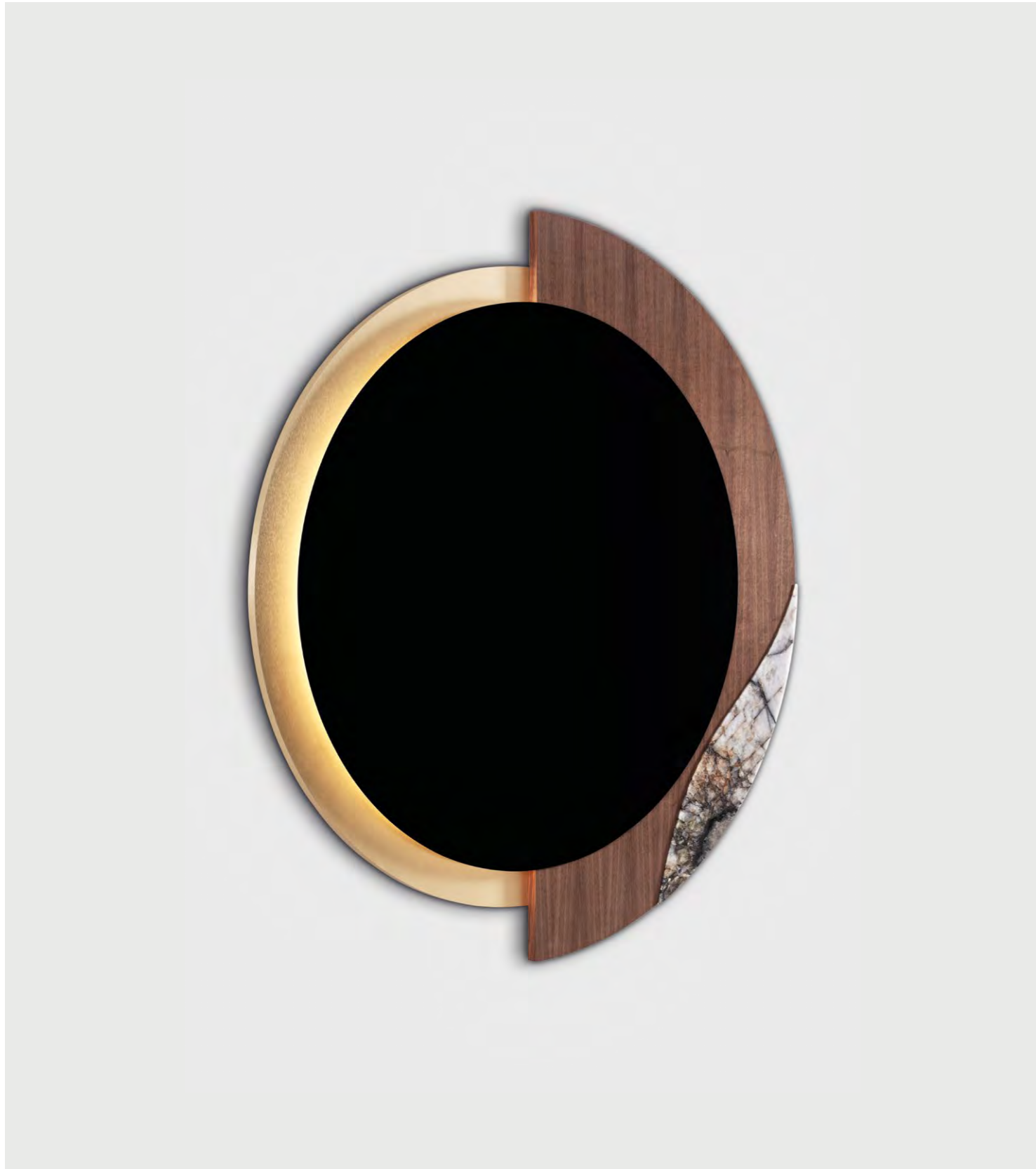

Farol

Magic mirror

G702399

Round magic mirror with a built-in UHD 4K 49" TV set. Wooden structure inlaid composition in walnut veneer satin finish, brushed brass matt finish and polished Patagonia granite.



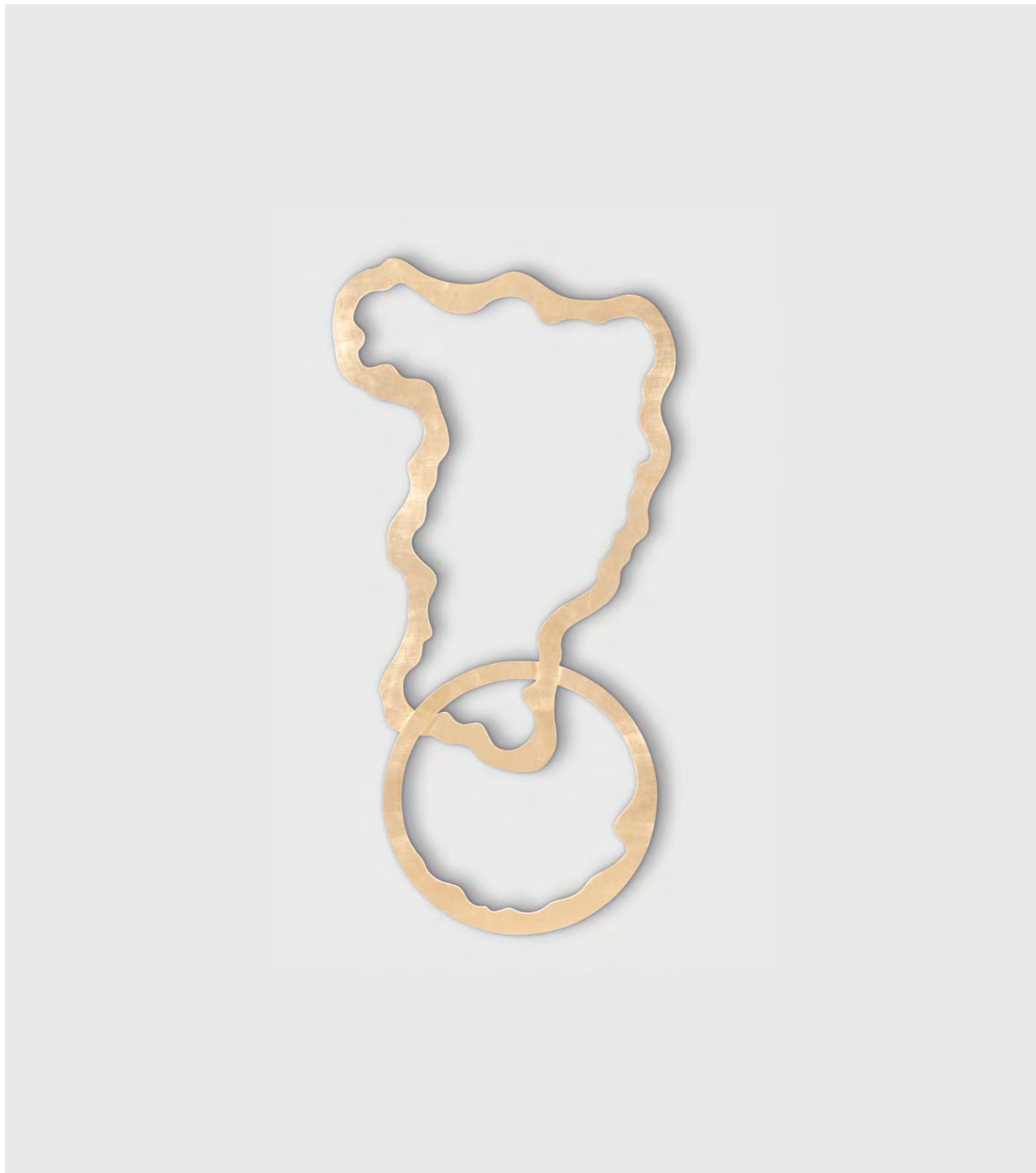

7 Cidades

Decorative wall piece

G702481

Wooden decorative wall piece with a gold leaf gilding satin finish. With warm white LED strip light included.



Ignis

Decorative wall piece

G702217

Decorative wall piece in polished Patagonia granite with a bronze-coloured glass shelf. Wooden back structure with gold leaf gilding with a high-gloss finish. Limited edition.



Ignis

Decorative wall piece

G702858

Decorative wall piece in polished Patagonia granite with a bronze-coloured glass shelf. Wooden back structure lacquered in satin grey. Limited edition.



Sun and Sand

Decorative wall mirror

G703104

Decorative wall mirror in brushed brass with a matt finish and two round clear crystal mirrors. Wooden back structure lacquered in high-gloss silver bronze powder. With warm white LED strip light included.





Breeze

Decorative wall piece

G703053

Decorative wall piece in fibreglass lacquered in a satin grey textured effect.
With warm white LED strip light included.

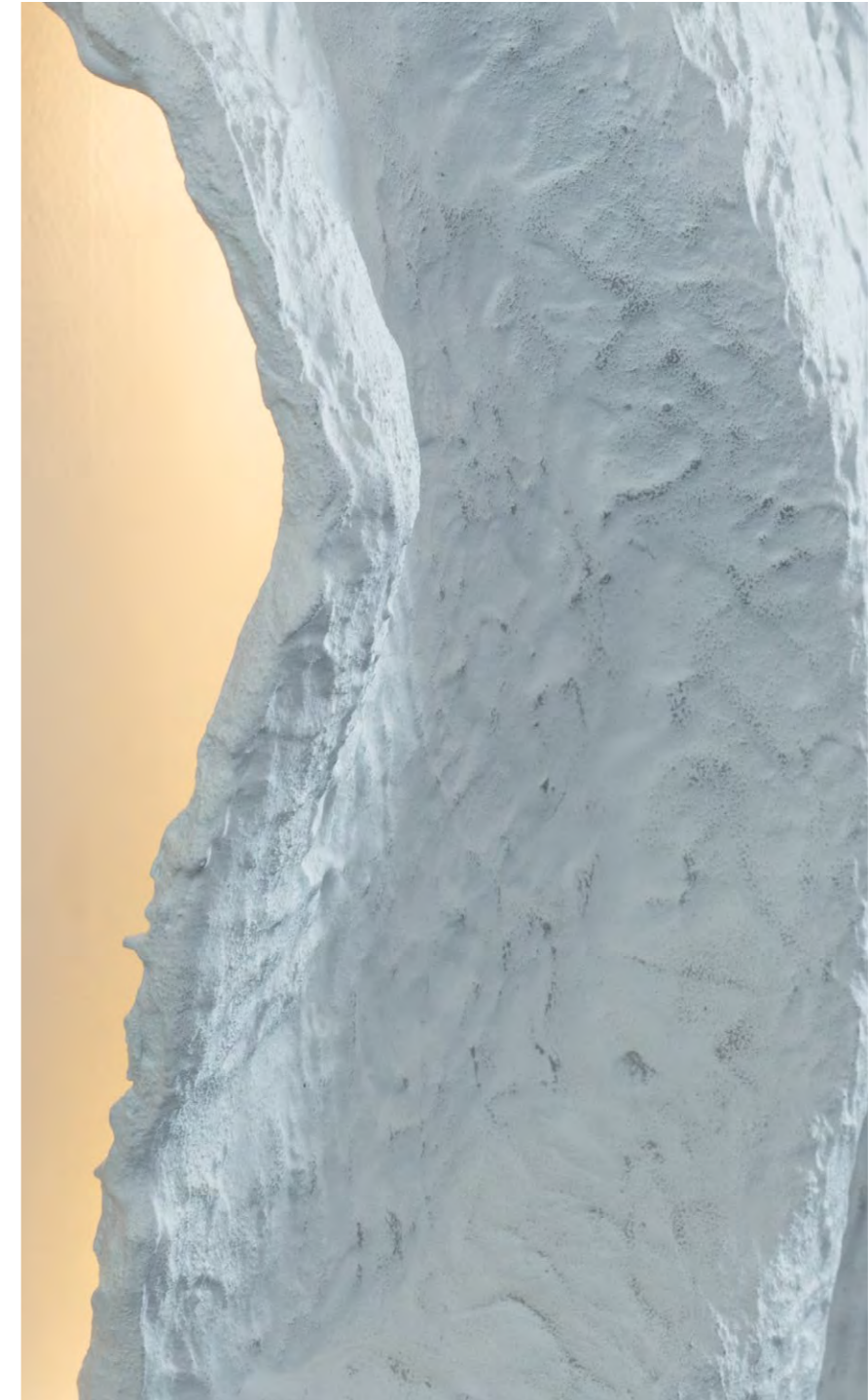

Handmade textured effect



Handmade textured effect

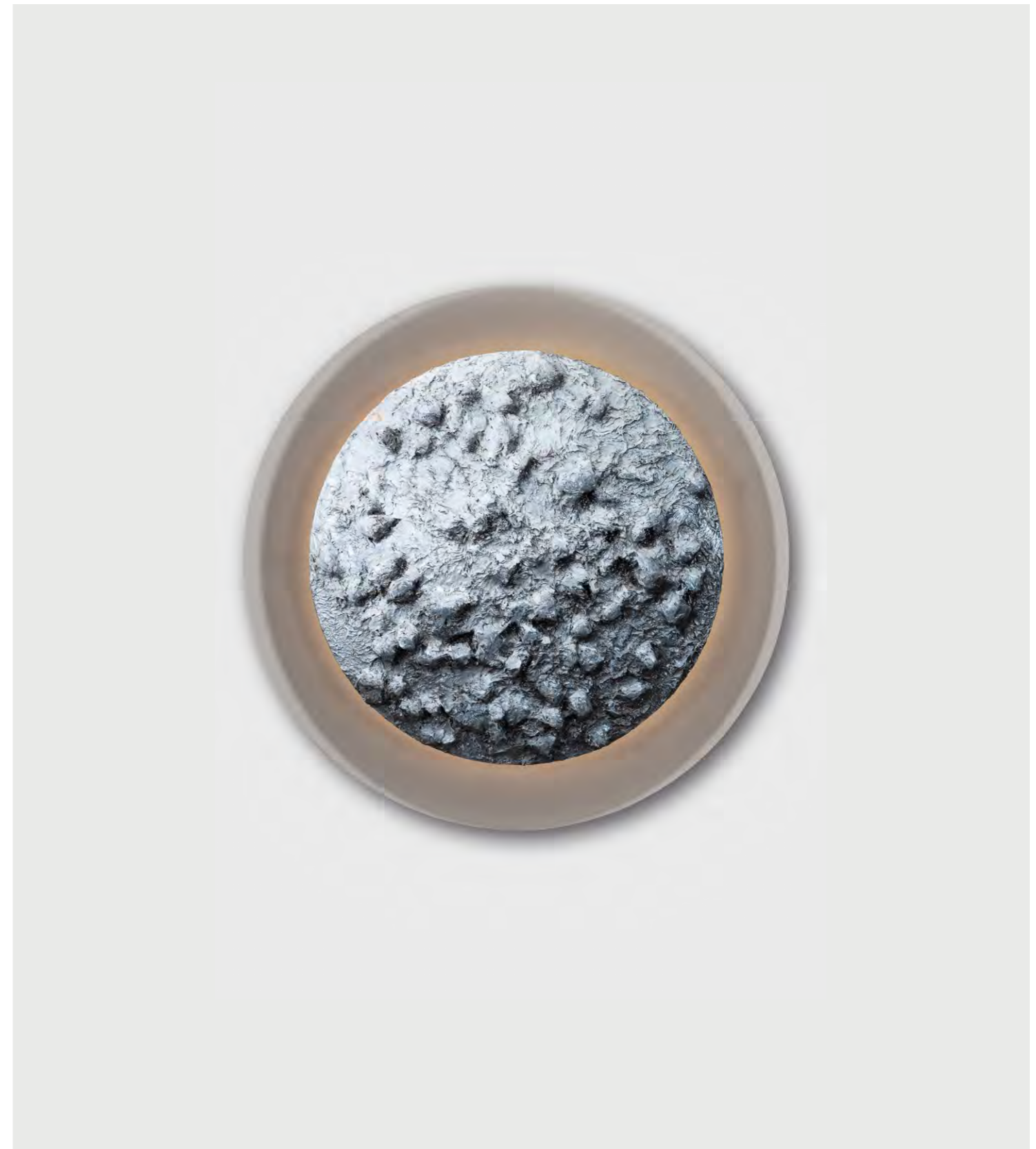

Moon
Decorative wall piece

G702487

Decorative wall piece in fibreglass lacquered in a grey bronze powder with a textured effect. Round acrylic structure on the back. With warm white LED strip light included.

Technical info

Bongó

Bar cabinet

076

DIMENSIONS

Width
171 cm · 67,3 in

Depth
54 cm · 21,3 in

Height
196 cm · 77,2 in

MATERIALS & FINISHES

Ref. G703150
FI073 Champagne bronze powder; high-gloss finish
WD075 Walnut; natural colour; matt finish
ST041 Sahara Noir marble; polished
ST042 Patagonia granite; polished
ME007 Oxidised brass; high-gloss finish
EL001 LED light strip

TECHNICAL

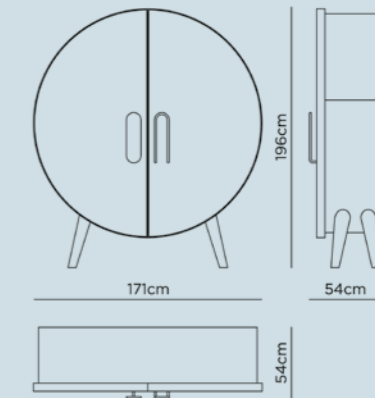

Saqrís

Cabinet

080

DIMENSIONS

Width
110 cm · 43,3 in

Depth
55 cm · 21,7 in

Height
195 cm · 76,8 in

MATERIALS & FINISHES

Ref. G702229
FI007 Black lacquer; satin finish
ME006 Brushed brass; high-gloss finish
EL001 LED light strip

TECHNICAL

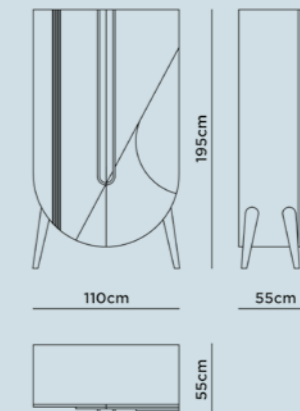

Lage

Bookcase

084

DIMENSIONS

Width
200 cm · 78,7 in

Depth
38 cm · 15 in

Height
240 cm · 94,5 in

MATERIALS & FINISHES

Ref. G703082
FI007 Black lacquer; satin finish
WD075 Walnut; natural colour; matt finish
ME032 Oxidised brass; matt finish
ME029 Dark oxidised brass; matt finish

TECHNICAL

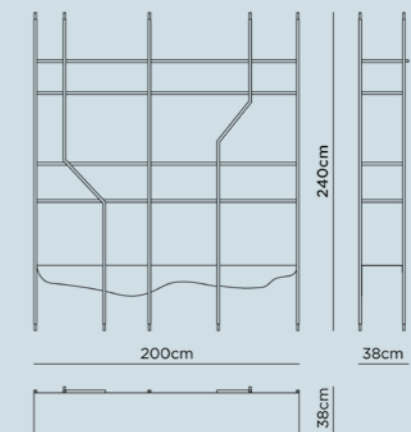

Hobart

Bookcase

088

DIMENSIONS

Width
290 cm · 114,2 in

Depth
40 cm · 15,7 in

Height
240 cm · 94,5 in

MATERIALS & FINISHES

Ref. [G701748](#)
 FIO07 Black lacquer;
 satin finish
 FIO73 Champagne bronze
 powder; high-gloss finish
 FI126 Gold bronze powder
 with a patina effect;
 satin finish
 WD027 American oak;
 open-pore natural colour;
 matt finish

TECHNICAL

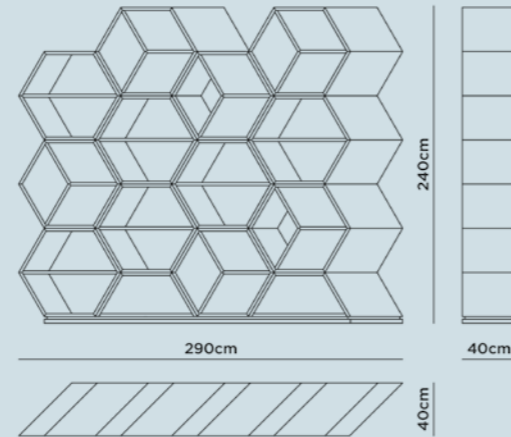

Hobart

Bookcase

090

DIMENSIONS

Width
170 cm · 66,9 in

Depth
35 cm · 13,8 in

Height
240 cm · 94,5 in

MATERIALS & FINISHES

Ref. [G702526](#)
 WD075 Walnut; natural
 colour; matt finish
 FIO73 Champagne bronze
 powder; high-gloss finish

TECHNICAL

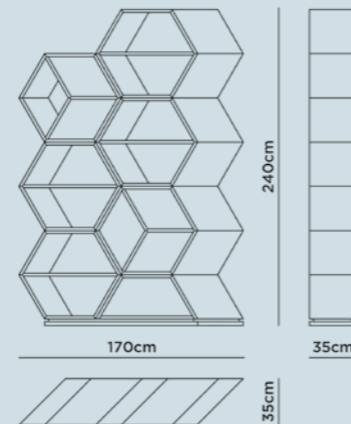

Biloba

Sideboard

094

DIMENSIONS

Width
220 cm · 86,6 in

Depth
50 cm · 19,7 in

Height
80 cm · 31,5 in

MATERIALS & FINISHES

Ref. [G702194](#)
 WD085 Eucalyptus *frisé*;
 natural colour; high-gloss
 finish
 FI136 Dark green lacquer;
 satin finish
 ST005 Green Guatemala
 marble; polished
 ST010 Calacatta Crema
 marble; polished
 ST033 Verde Antigua
 marble; polished
 ST037 Rosa Egeo marble;
 polished
 ME006 Brushed brass;
 high-gloss finish
 EL001 LED light strip

TECHNICAL

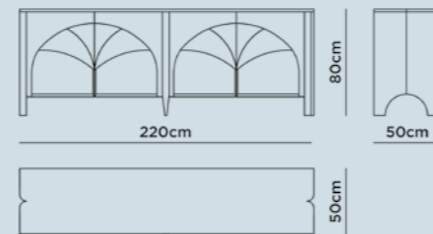

Olival

Sideboard

076

DIMENSIONS

Width
220 cm · 86,6 in

Depth
55 cm · 21,7 in

Height
60 cm · 23,6 in

MATERIALS & FINISHES

Ref. [G702419](#)
 WD026 American oak;
 open-pore dark brown
 stained; matt finish
 ME006 Brushed brass;
 high-gloss finish
 ST043 Calacatta Viola
 marble; polished
 FIO07 Black lacquer;
 satin finish
 EL001 LED light strip

TECHNICAL

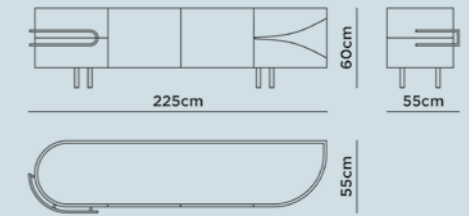

Sunshine

Sideboard

102

DIMENSIONS

Width
190 cm · 74,8 in

Depth
50 cm · 19,7 in

Height
86 cm · 33,9 in

MATERIALS & FINISHES

Ref. [G702451](#)
 FIO07 Black lacquer;
 satin finish
 FI143 Gold bronze powder
 with a sfumato effect;
 satin finish
 FI144 Bordeaux lacquer;
 satin finish
 FIO94 Gold leaf; satin finish
 ME026 Dark oxidised brass;
 high-gloss finish

TECHNICAL

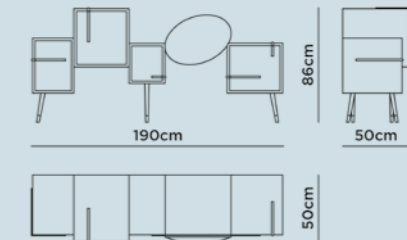

Armona

10-seater dining table

108

DIMENSIONS

Width
285 cm · 112,2 in

Depth
125 cm · 49,2 in

Height
75 cm · 29,5 in

MATERIALS & FINISHES

Ref. [G703132](#)
 WD026 American oak;
 open-pore dark brown
 stained; matt finish
 ME032 Oxidised brass;
 matt finish
 WD123 American oak;
 open-pore tobacco colour
 stained; eggshell finish
 WD124 Ash; open-pore
 dark brown stained;
 eggshell finish
 FIO07 Black lacquer;
 satin finish

TECHNICAL

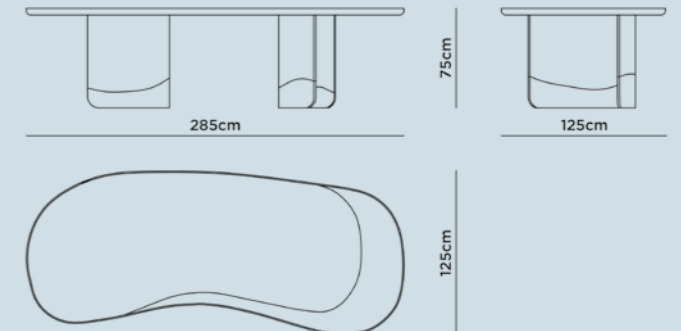

Olisippo

6-seater dining table

112

DIMENSIONS

Width
200 cm · 78,7 in

Depth
110 cm · 43,3 in

Height
77 cm · 30,3 in

MATERIALS & FINISHES

Ref. [G702273](#)
WD066 Beech; dark brown stained; high-gloss finish
ME005 Polished brass; high-gloss finish
ST042 Patagonia granite; polished
EL001 LED light strip

TECHNICAL

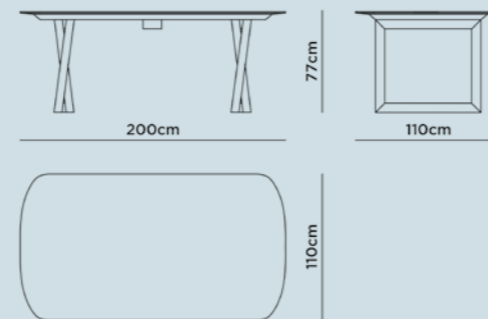

Ferreirinha

6-seater dining table

114

DIMENSIONS

Ø
160 cm · 63 in

Height
78 cm · 30,7 in

MATERIALS & FINISHES

Ref. [G702478](#)
M102714 Dark red high standard Italian leather
WD107 American oak; open-pore black stained; matt finish
FI112 Light gold bronze powder with a patina effect; satin finish
ST044 Calacatta Black Vein marble; polished

TECHNICAL

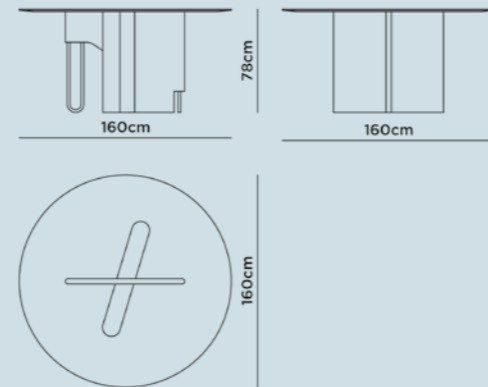

Ferreirinha

6-seater dining table

118

DIMENSIONS

Ø
150 cm · 59,1 in

Height
78 cm · 30,7 in

MATERIALS & FINISHES

Ref. [G702291](#)
M100873 White dyed leather with geometrical embossing and metallic hand finishing
WD018 American oak; natural colour; satin finish
ME006 Brushed brass; high-gloss finish
ST027 Calacatta Bianco marble; matt finish

TECHNICAL

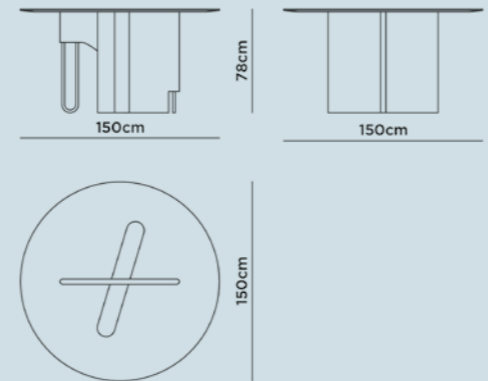

Castelo

Console

120

DIMENSIONS

Width
160 cm · 63,0 in

Depth
48 cm · 18,9 in

Height
80 cm · 31,5 in

MATERIALS & FINISHES

Ref. [G702277](#)
FI073 Champagne bronze powder; high-gloss finish
FI007 Black lacquer; satin finish
ST041 Sahara Noir marble; polished

TECHNICAL

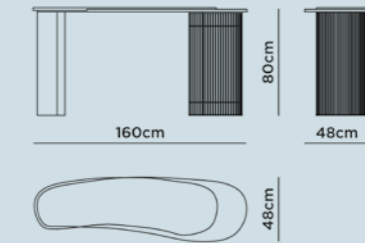

Chiado

Console

122

DIMENSIONS

Width
170 cm · 66,9 in

Depth
49 cm · 19,3 in

Height
78 cm · 30,7 in

MATERIALS & FINISHES

Ref. [G702343](#)
ST042 Patagonia granite; polished
FI007 Black lacquer; satin finish
FI073 Champagne bronze powder; high-gloss finish
M103198 Dark red premium Italian leather
EL001 LED light strip

TECHNICAL

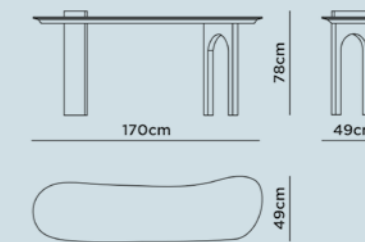

Menir

Console

126

DIMENSIONS

Width
180 cm · 70,9 in

Depth
48 cm · 18,9 in

Height
75 cm · 29,5 in

MATERIALS & FINISHES

Ref. [G702421](#)
WD107 American oak; open-pore black stained; matt finish
FI007 Black lacquer; satin finish
FI073 Champagne bronze powder; high-gloss finish
ST044 Calacatta Black Vein marble; polished

TECHNICAL

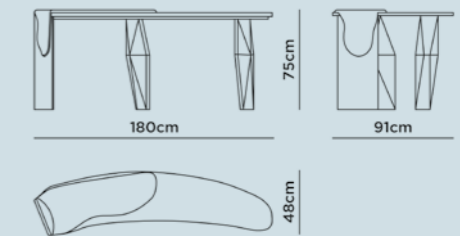

Alma

Console

128

DIMENSIONS

Width
160 cm · 63,0 in

Depth
45 cm · 17,7 in

Height
60 cm · 23,6 in

MATERIALS & FINISHES

Ref. [G702485](#)
F1145 Dark blue-grey;
high-gloss finish
ME026 Dark oxidised brass;
high-gloss finish
F1007 Black lacquer;
satin finish

TECHNICAL

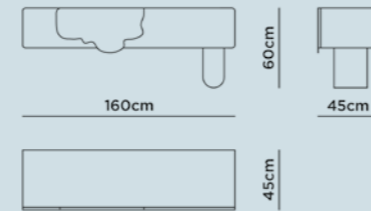

Armona

Coffee table

136

DIMENSIONS

Width
150 cm · 59,1 in

Depth
46 cm · 18,1 in

Height
30 cm · 11,8 in

MATERIALS & FINISHES

Ref. [G703133](#)
WD107 American oak;
open-pore black stained;
matt finish
ME029 Dark oxidised brass;
matt finish
ST003 Shadow onyx;
polished

TECHNICAL

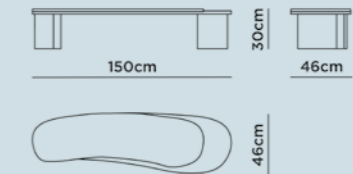

Armona

Desk

131

DIMENSIONS

Width
180 cm · 70,9 in

Depth
65 cm · 25,6 in

Height
76 cm · 29,9 in

MATERIALS & FINISHES

Ref. [G703031](#)
F1073 Champagne bronze
powder; high-gloss finish
WD075 Walnut; natural
colour; matt finish
ME026 Dark oxidised brass;
high-gloss finish
ST003 Shadow onyx;
polished
EL005 USB port

TECHNICAL

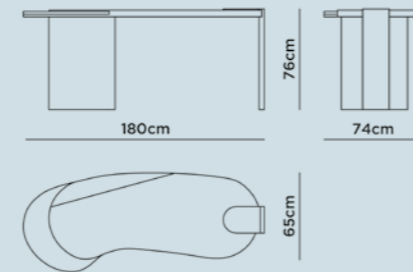

Sistelo

Coffee table

140

DIMENSIONS

Width
110 cm · 43,3 in

Depth
76 cm · 29,9 in

Height
38 cm · 15 in

MATERIALS & FINISHES

Ref. [G702470](#)
F1007 Black lacquer;
satin finish
F1073 Champagne bronze
powder; high-gloss finish
ME006 Brushed brass;
high-gloss finish
WD106 Oak root; natural
colour; satin finish

TECHNICAL

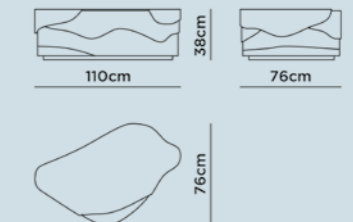

Bordeira

Coffee table

134

DIMENSIONS

Width
111 cm · 43,7 in

Depth
100 cm · 39,4 in

Height
30 cm · 11,8 in

MATERIALS & FINISHES

Ref. [G703117](#)
WD107 American oak;
open-pore black stained;
matt finish
WD110 Beech; black
stained; matt finish
ST003 Shadow onyx;
polished

TECHNICAL

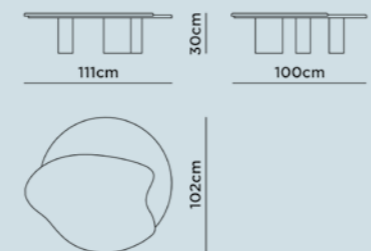

Aire

Coffee table

144

DIMENSIONS

Width
200 cm · 78,7 in

Depth
55 cm · 21,7 in

Height
30 cm · 11,8 in

MATERIALS & FINISHES

Ref. [G703096](#)
F1007 Black lacquer;
satin finish
ME007 Oxidised brass;
high-gloss finish
ST056 Bardiglio marble;
matt finish

TECHNICAL

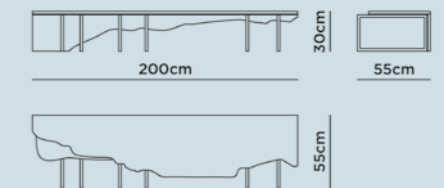

Aire

Coffee table

148

DIMENSIONS	MATERIALS & FINISHES	TECHNICAL
<p>Width</p> <p>120 cm · 47,2 in</p> <p>Depth</p> <p>70 cm · 27,6 in</p> <p>Height</p> <p>35 cm · 13,8 in</p>	<p>Ref. G702420</p> <p>FI007 Black lacquer; satin finish</p> <p>ME026 Dark oxidised brass; high-gloss finish</p> <p>ST046 Nero Marquina marble; matt finish</p>	

Mó

Coffee table

150

DIMENSIONS	MATERIALS & FINISHES	TECHNICAL
<p>Ø</p> <p>80 cm · 31,5 in</p> <p>Height</p> <p>40 cm · 15,7 in</p>	<p>Ref. G702467</p> <p>WD108 Aged American oak; open-pore dark brown stained; matt finish</p> <p>ME026 Dark oxidised brass; high-gloss finish</p> <p>FI007 Black lacquer; satin finish</p> <p>FI112 Light gold bronze powder with a patina effect; satin finish</p>	

Infinity

Coffee table

152

DIMENSIONS	MATERIALS & FINISHES	TECHNICAL
<p>Width</p> <p>127 cm · 50,0 in</p> <p>Depth</p> <p>65 cm · 25,6 in</p> <p>Height</p> <p>35 cm · 13,8 in</p>	<p>Ref. 909147</p> <p>FI043 White lacquer; high-gloss finish</p> <p>ST020 Calacatta Bianco marble; bush hammered</p> <p>ME001 Polished stainless steel</p> <p>GL009 Ultra clear glass</p>	

Dornes

Side table

154

DIMENSIONS	MATERIALS & FINISHES	TECHNICAL
<p>Width</p> <p>46 cm · 18,1 in</p> <p>Depth</p> <p>45 cm · 17,7 in</p> <p>Height</p> <p>45 cm · 17,7 in</p>	<p>Ref. G703094</p> <p>ME007 Oxidised brass; high-gloss finish</p> <p>WD106 Oak root; natural colour; satin finish</p>	

Aire

Side table

156

DIMENSIONS	MATERIALS & FINISHES	TECHNICAL
<p>Width</p> <p>37 cm · 14,6 in</p> <p>Depth</p> <p>38 cm · 15,0 in</p> <p>Height</p> <p>48 cm · 18,9 in</p>	<p>Ref. G703134</p> <p>FI007 Black lacquer; satin finish</p> <p>ME032 Oxidised brass; matt finish</p> <p>ST056 Bardiglio marble; matt finish</p>	

Aire

Side table

158

DIMENSIONS	MATERIALS & FINISHES	TECHNICAL
<p>Ø</p> <p>33 cm · 13 in</p> <p>Height</p> <p>37 cm · 14,6 in</p>	<p>Ref. G703135</p> <p>FI007 Black lacquer; satin finish</p> <p>ME032 Oxidised brass; matt finish</p> <p>ST046 Nero Marquina marble; matt finish</p>	

Pico

Side table

161

DIMENSIONS

∅
33 cm · 13 in

Height
51 cm · 20,1 in

MATERIALS & FINISHES

Ref. [G703118](#)
ST054 Silver Portoro
marble; matt finish
ME032 Oxidised brass;
matt finish

Ref. [G703148](#)
ST055 Grey coral stone;
matt finish
ME032 Oxidised brass;
matt finish

TECHNICAL

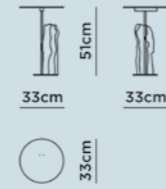
**Pico**

Side table

166

DIMENSIONS

∅
33 cm · 13 in

Height
40 cm · 15,7 in

MATERIALS & FINISHES

Ref. [G703119](#)
ST055 Grey coral stone;
matt finish
ME030 Brushed brass; matt
finish

Ref. [G703149](#)
ST046 Nero Marquina
marble; matt finish
ME030 Brushed brass;
matt finish

TECHNICAL

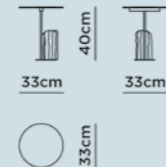
**Foice**

Side table

169

DIMENSIONS

∅
40 cm · 15,7 in

Height
50 cm · 19,7 in

MATERIALS & FINISHES

Ref. [G702466](#)
FI007 Black lacquer;
satin finish
ST027 Calacatta Bianco
marble; matt finish
ME026 Dark oxidised brass;
high-gloss finish

TECHNICAL

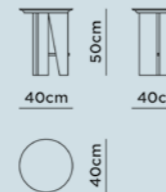
**Raw**

Side table

170

DIMENSIONS

Width
38 cm · 15,0 in

Depth
38 cm · 15,0 in

Height
42 cm · 16,5 in

MATERIALS & FINISHES

Ref. [G702468](#)
FI007 Black lacquer;
satin finish
ME006 Brushed brass;
high-gloss finish
ST041 Sahara Noir marble;
polished

TECHNICAL

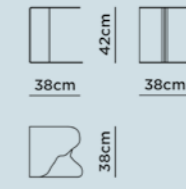
**Eleanor**

Chair with armrests

174

DIMENSIONS

Width
64 cm · 25,2 in

Depth
55 cm · 21,7 in

Height
75 cm · 29,5 in

MATERIALS & FINISHES

Ref. [G702486](#)
FI007 Black lacquer;
satin finish
M102585 Beige woven
textured fabric
M102596 Jacquard velvet
with a black pied de poule
pattern

TECHNICAL

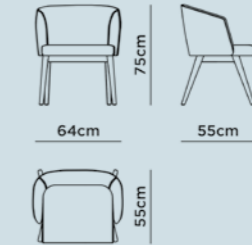
**De Castro**

Chair

176

DIMENSIONS

Width
60 cm · 23,6 in

Depth
67 cm · 26,4 in

Height
103 cm · 40,6 in

MATERIALS & FINISHES

Ref. [909718](#)
WD005 Beech; dark brown
stained; satin finish
WD056 Ebony; natural
colour; high-gloss finish
M100384 Ruby-pink cotton
velvet

TECHNICAL

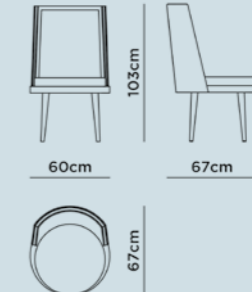

Laurence

Chair with armrests

180

DIMENSIONS

Width
56 cm · 22,0 in

Depth
55 cm · 21,7 in

Height
81 cm · 31,9 in

MATERIALS & FINISHES

Ref. [G702247](#)
M102568 Yellow cotton velvet

Ref. [G702298](#)
M102230 Grey technical fabric

Ref. [G702978](#)
M103421 Blue high standard Italian leather

Ref. [G703137](#)
M103640 Greyish-green nubuck velvet leather

TECHNICAL

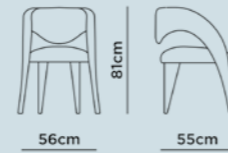

Maia

Chair with armrests

186

DIMENSIONS

Width
60 cm · 23,6 in

Depth
52 cm · 20,5 in

Height
80 cm · 31,5 in

MATERIALS & FINISHES

Ref. [G703076](#)
FI007 Black lacquer; satin finish

FI026 Gold bronze powder; high-gloss finish
M103647 Caramel premium Italian leather

TECHNICAL

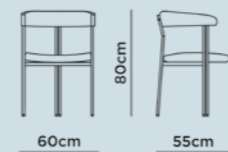

Mary

Bar chair

190

DIMENSIONS

Width
54 cm · 21,3 in

Depth
55 cm · 21,7 in

Height
111 cm · 43,7 in

MATERIALS & FINISHES

Ref. [G703142](#)
WD111 Beech; black stained; satin finish
ME030 Brushed brass; matt finish
M103422 Caramel high standard Italian leather

Ref. [G702873](#)
WD005 Beech; dark brown stained; satin finish
ME029 Dark oxidised brass; matt finish
M103277 Red premium Italian leather

Ref. [G702549](#)
WD005 Beech; dark brown stained; satin finish
ME006 Brushed brass; high-gloss finish
M102491 Navy blue high standard Italian leather

TECHNICAL



Galapinhos

4-seater sofa

196

DIMENSIONS

Width
319 cm · 125,6 in

Depth
158 cm · 62,2 in

Height
80 cm · 31,5 in

MATERIALS & FINISHES

Ref. [G703101](#)
M103641 Caramel nubuck velvet leather
WD107 American oak; open-pore black stained; matt finish

TECHNICAL

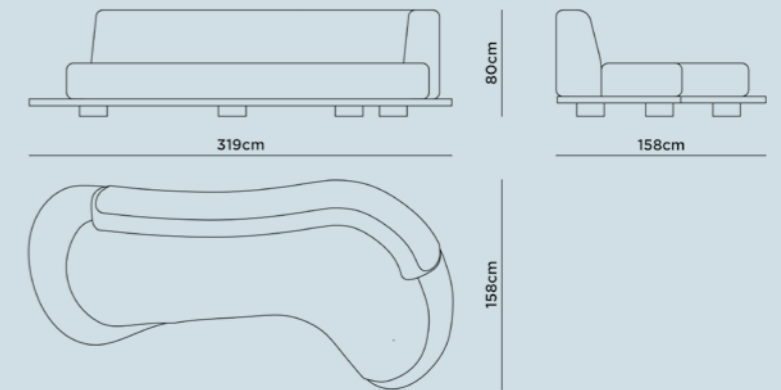

Almourol

4-seater sofa

198

DIMENSIONS

Width
280 cm · 110,2 in

Depth
91 cm · 35,8 in

Height
80 cm · 31,5 in

MATERIALS & FINISHES

Ref. [G703102](#)
WD110 Beech; black stained; matt finish
M103520 Olive-green premium Italian leather

TECHNICAL

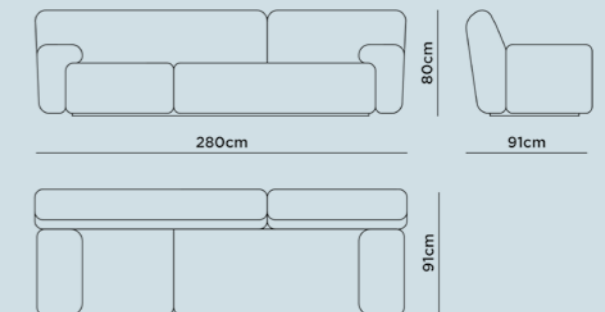

Beijinho

4-seater sofa

202

DIMENSIONS

Width
280 cm · 110,2 in

Depth
92 cm · 36,2 in

Height
80 cm · 31,5 in

MATERIALS & FINISHES

Ref. [G703099](#)
WD110 Beech; black stained; matt finish
M103520 Olive-green premium Italian leather

TECHNICAL

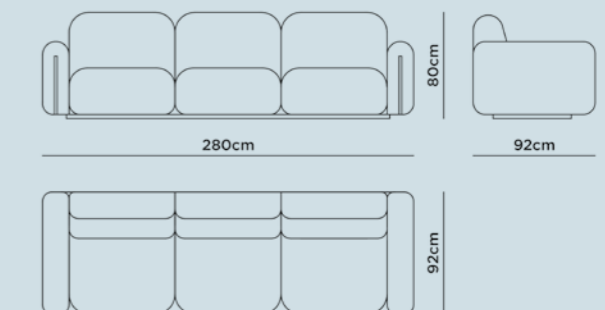

Beijinho

3-seater sofa

204

DIMENSIONS

Width
240 cm · 94,5 in

Depth
100 cm · 39,4 in

Height
80 cm · 31,5 in

MATERIALS & FINISHES

Ref. [G702863](#)
WD005 Beech; dark brown stained; satin finish
M102184 Gold-coloured dyed leather
M102599 Beige jacquard-patterned velvet

TECHNICAL

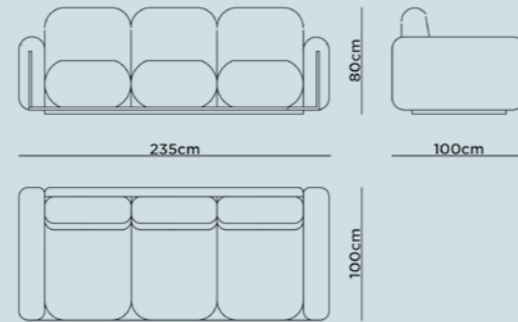

Beijinho

Sofa with chaise longue

206

DIMENSIONS

Width
300 cm · 118,1 in

Depth
185 cm · 72,8 in

Height
80 cm · 31,5 in

MATERIALS & FINISHES

Ref. [G702342](#)
FI026 Gold bronze powder; high-gloss finish
M102599 Beige jacquard-patterned velvet

TECHNICAL

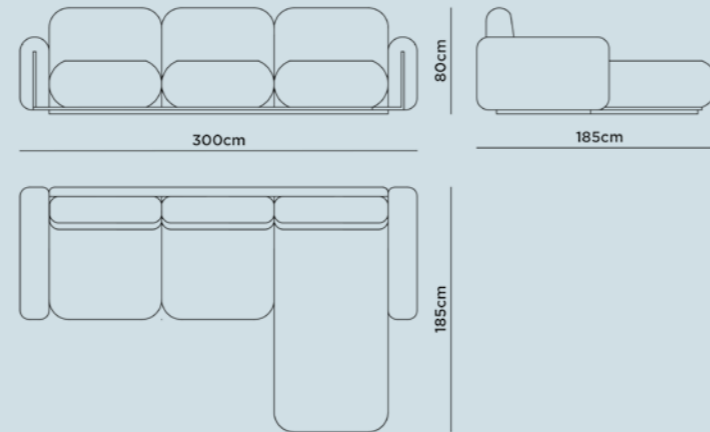

Beijinho

Single sofa

208

DIMENSIONS

Width
110 cm · 43,3 in

Depth
100 cm · 39,4 in

Height
80 cm · 31,5 in

MATERIALS & FINISHES

Ref. [G702334](#)
WD005 Beech; dark brown stained; satin finish
M102184 Gold-coloured dyed leather
M102599 Beige jacquard-patterned velvet

TECHNICAL

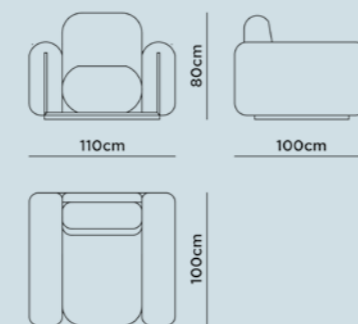

Twins

4-seater sofa

210

DIMENSIONS

Width
280 cm · 110,2 in

Depth
112 cm · 44,1 in

Height
75 cm · 29,5 in

MATERIALS & FINISHES

Ref. [G703009](#)
FI116 Brown-gold bronze powder with a patina effect; eggshell finish
M103554 Pearl cotton-linen blend bouclé fabric

TECHNICAL

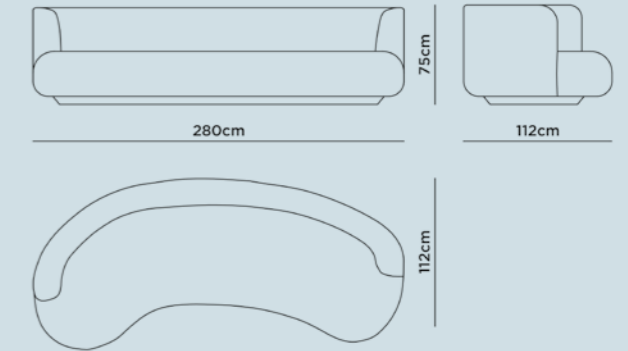

Twins

3-seater sofa

212

DIMENSIONS

Width
207 cm · 81,5 in

Depth
112 cm · 44,1 in

Height
75 cm · 29,5 in

MATERIALS & FINISHES

Ref. [G702404](#)
FI007 Black lacquer; satin finish
M102593 Grey cotton-linen blend bouclé fabric

TECHNICAL

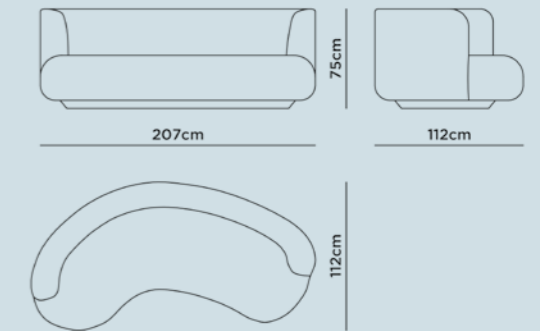

Twins

Chaise longue

218

DIMENSIONS

Width
185 cm · 72,8 in

Depth
100 cm · 39,4 in

Height
65 cm · 25,6 in

MATERIALS & FINISHES

Ref. [G702734](#)
FI007 Black lacquer; satin finish
M103109 Blue-grey nubuck velvet leather

TECHNICAL

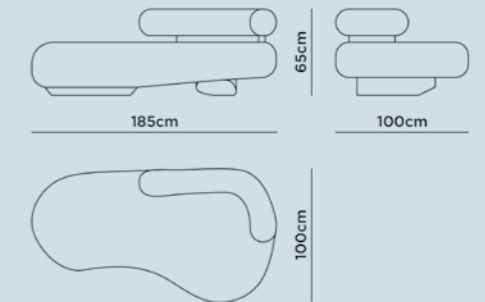

Minho

Chaise longue

222

DIMENSIONS

Width
195 cm · 76,8 in

Depth
95 cm · 37,4 in

Height
55 cm · 21,7 in

MATERIALS & FINISHES

Ref. [G702482](#)
WD075 Walnut; natural
colour; matt finish
M100388 Red cotton velvet

TECHNICAL

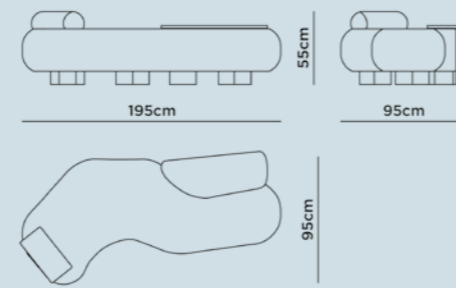

Mel

Armchair

224

DIMENSIONS

Width
95 cm · 37,4 in

Depth
100 cm · 39,4 in

Height
91 cm · 35,8 in

MATERIALS & FINISHES

Ref. [G702710](#)
M102598 Beige jacquard
velvet with a leaf pattern
M103554 Pearl cotton-linen
blend bouclé fabric
ME030 Brushed brass;
matt finish

TECHNICAL

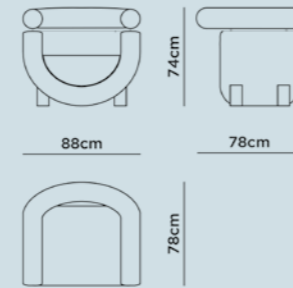

Barão

Armchair

228

DIMENSIONS

Width
84 cm · 33,1 in

Depth
103 cm · 40,6 in

Height
95 cm · 37,4 in

MATERIALS & FINISHES

Ref. [G703080](#)
WD011 Beech; dark brown
stained; matt finish
M103648 Dark green
premium Italian leather
M103110 Light grey nubuck
velvet leather

Ref. [G703175](#)
WD011 Beech; dark brown
stained; matt finish
M103648 Dark green
premium Italian leather
M103641 Caramel nubuck
velvet leather

TECHNICAL

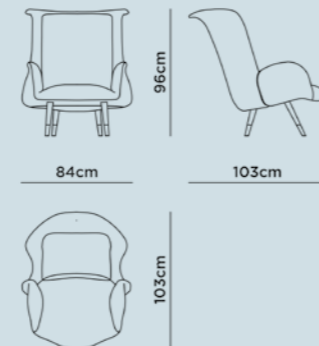

Capelinhos

Armchair

234

DIMENSIONS

Width
84 cm · 33,1 in

Depth
95 cm · 37,4 in

Height
87 cm · 34,3 in

MATERIALS & FINISHES

Ref. [G702697](#)
FI007 Black lacquer;
satin finish
M103585 Caramel premium
Italian leather

TECHNICAL

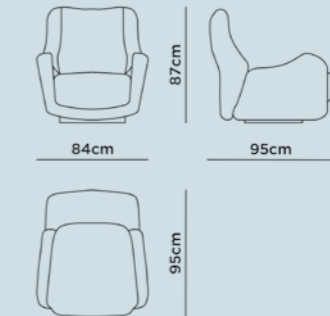

Caju

Armchair

236

DIMENSIONS

Width
60 cm · 23,6 in

Depth
60 cm · 23,6 in

Height
78 cm · 30,7 in

MATERIALS & FINISHES

Ref. [G703020](#)
ME032 Oxidised brass;
matt finish
M103430 Blue high
standard Italian leather

TECHNICAL

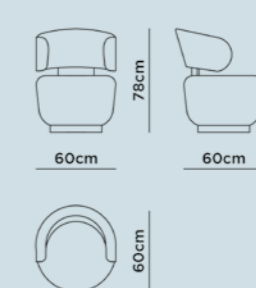

Caju

Armchair

240

DIMENSIONS

Width
75 cm · 29,5 in

Depth
75 cm · 29,5 in

Height
78 cm · 30,7 in

MATERIALS & FINISHES

Ref. [G703138](#)
M103676 White wool
bouclé fabric
G101326 White faux fur
ME032 Oxidised brass;
matt finish

Ref. [G702426](#)
FI073 Champagne bronze
powder; high-gloss finish
M102581 Blue-green
jacquard-patterned velvet

TECHNICAL

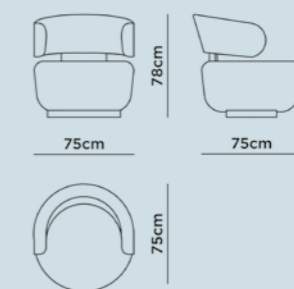

Mons

Chaise longue

244

DIMENSIONS

Width
125 cm · 49,2 in

Depth
65 cm · 25,6 in

Height
85 cm · 33,5 in

MATERIALS & FINISHES

Ref. [G702499](#)
FI073 Champagne bronze powder; high-gloss finish
M102710 Red high standard Italian leather

TECHNICAL

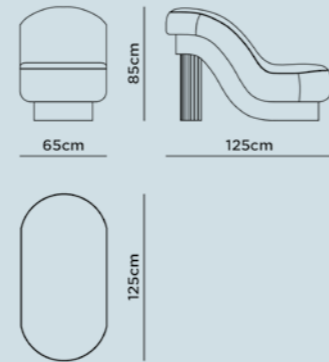

Forever

Chandelier

248

DIMENSIONS

Ø
66 cm · 26 in

Height
160 cm · 63,0 in

MATERIALS & FINISHES

Ref. [G702522](#)
ME001 Polished stainless steel
WD108 Aged American oak; open-pore dark brown stained; matt finish
ME033 Aluminium chain
EL002 E27 LED lamp

TECHNICAL



Pessoa

Suspension lamp

250

DIMENSIONS

Width
45 cm · 17,7 in

Depth
25 cm · 9,8 in

Height
120 cm · 47,2 in

MATERIALS & FINISHES

Ref. [G702227](#)
ST045 Carrara Bianco marble; polished
ME006 Brushed brass; high-gloss finish
WD027 American oak; open-pore natural colour; matt finish
FI042 White lacquer; satin finish
EL001 LED light strip

TECHNICAL

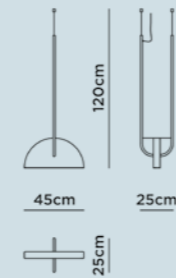

Two

Table lamp

253

DIMENSIONS

Width
61 cm · 24,0 in

Depth
13 cm · 5,1 in

Height
60 cm · 23,6 in

MATERIALS & FINISHES

Ref. [G703145](#)
ME006 Brushed brass; high-gloss finish
ME026 Dark oxidised brass; high-gloss finish
ST031 Statuario marble; polished
EL004 G4 LED lamp
GL013 Frosted glass

TECHNICAL

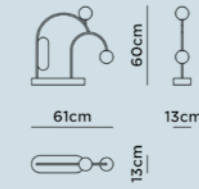

Bobo

Table lamp

254

DIMENSIONS

Width
28 cm · 11,0 in

Depth
13 cm · 5,1 in

Height
41 cm · 16,1 in

MATERIALS & FINISHES

Ref. [G702578](#)
FI073 Champagne bronze powder; high-gloss finish
EL003 G9 LED lamp
GL013 Frosted glass

TECHNICAL

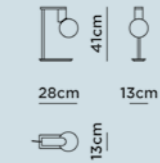

Tosco

Table lamp

256

DIMENSIONS

Width
36 cm · 14,2 in

Depth
21 cm · 8,3 in

Height
41 cm · 16,1 in

MATERIALS & FINISHES

Ref. [G702579](#)
FI073 Champagne bronze powder; high-gloss finish
EL001 LED light strip

TECHNICAL



Lima

Table lamp

257

DIMENSIONS

Width
52 cm · 20,5 in

Depth
12 cm · 4,7 in

Height
43 cm · 16,9 in

MATERIALS & FINISHES

Ref. [G702577](#)
FI073 Champagne bronze powder; high-gloss finish
ELO01 LED light strip

TECHNICAL

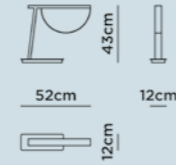

Sublime

Floor lamp

261

DIMENSIONS

Width
240 cm · 94,5 in

Depth
60 cm · 23,6 in

Height
185 cm · 72,8 in

MATERIALS & FINISHES

Ref. [G701795](#)
ST012 Nero Marquina marble; polished
ME001 Polished stainless steel
M103850 Black pure silk
ELO02 E27 LED lamp

TECHNICAL

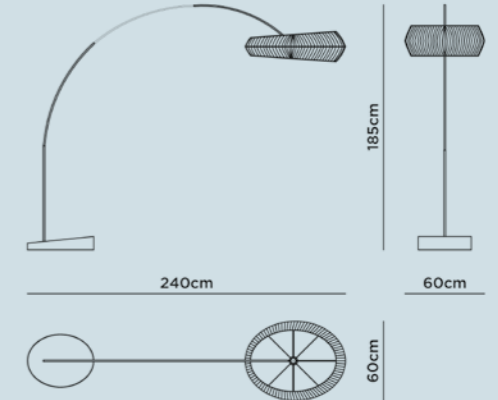

Opposite

Floor lamp

258

DIMENSIONS

Width
45 cm · 17,7 in

Depth
20 cm · 7,9 in

Height
170 cm · 66,9 in

MATERIALS & FINISHES

Ref. [G702690](#)
ME006 Brushed brass; high-gloss finish
ST053 Silver Portoro marble; polished
FI007 Black lacquer; satin finish
WD107 American oak; open-pore black stained; matt finish
ELO01 LED light strip

TECHNICAL

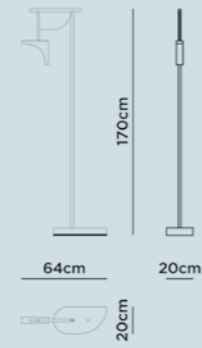

Sublime

Floor lamp

262

DIMENSIONS

Width
60 cm · 23,6 in

Depth
50 cm · 19,7 in

Height
170 cm · 66,9 in

MATERIALS & FINISHES

Ref. [G702296](#)
ST012 Nero Marquina marble; polished
ME001 Polished stainless steel
M103850 Black pure silk
ELO02 E27 LED lamp

TECHNICAL

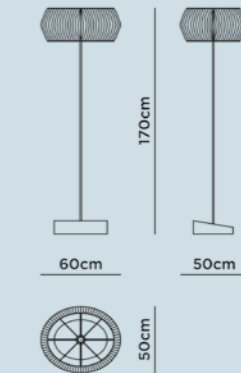

Lima

Floor lamp

260

DIMENSIONS

Width
150 cm · 59,1 in

Depth
40 cm · 15,7 in

Height
180 cm · 70,9 in

MATERIALS & FINISHES

Ref. [G702498](#)
WD012 Beech; natural colour; matt finish
FI073 Champagne bronze powder; high-gloss finish
ST027 Calacatta Bianco marble; matt finish
ME001 Polished stainless steel
ELO01 LED light strip

TECHNICAL

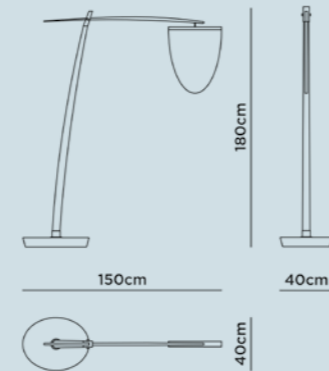

Opposite

Wall lamp

264

DIMENSIONS

Width
126 cm · 49,6 in

Depth
20 cm · 7,9 in

Height
73 cm · 28,7 in

MATERIALS & FINISHES

Ref. [G702692](#)
FI007 Black lacquer; satin finish
ELO01 LED light strip

TECHNICAL

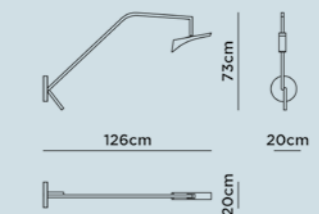

Rossim

Decorative wall piece

268

DIMENSIONS

Width
40 cm · 15,7 in

Depth
6 cm · 2,4 in

Height
54 cm · 21,3 in

MATERIALS & FINISHES

Refs. [G702471](#) · [G702520](#)
ME006 Brushed brass;
high-gloss finish
WD027 American oak;
open-pore natural colour;
matt finish
ST047 Statuario marble;
matt finish
EL001 LED light strip

TECHNICAL

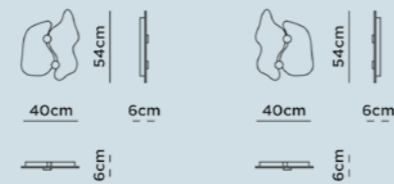

Flute

Mirror

271

DIMENSIONS

Width
130 cm · 51,2 in

Depth
5 cm · 2 in

Height
170 cm · 66,9 in

MATERIALS & FINISHES

Ref. [G702248](#)
FI026 Gold bronze powder;
high-gloss finish
MI001 Clear crystal mirror

TECHNICAL

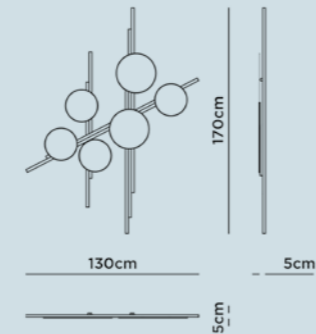

Bubbles 10

Mirror

272

DIMENSIONS

Width
120 cm · 47,2 in

Depth
4 cm · 1,6 in

Height
65 cm · 25,6 in

MATERIALS & FINISHES

Ref. [G700705](#)
FI042 White lacquer;
satin finish
FI029 Silver bronze powder
with a textured and patina
effect; high-gloss finish
MI001 Clear crystal mirror
ST012 Nero Marquina
marble; polished
ST031 Statuario marble;
polished

Ref. [G702491](#)
FI042 White lacquer;
satin finish
FI029 Silver bronze powder
with a textured and patina
effect; high-gloss finish
MI001 Clear crystal mirror
ST041 Sahara Noir marble;
polished
ST031 Statuario marble;
polished

TECHNICAL

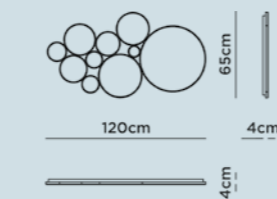

Farol

Magic mirror

274

DIMENSIONS

Width
185 cm · 72,8 in

Depth
11 cm · 4,3 in

Height
200 cm · 78,7 in

MATERIALS & FINISHES

Ref. [G702399](#)
ST042 Patagonia granite;
polished
WD076 Walnut; natural
colour; satin finish
ME030 Brushed brass;
matt finish
EL001 LED light strip

TECHNICAL

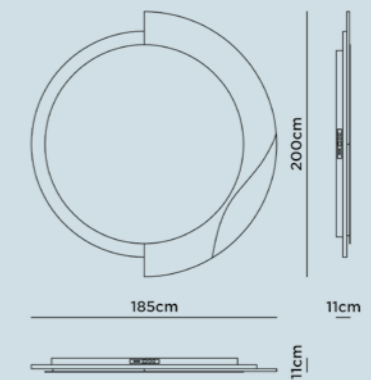

7 Cidades

Decorative wall piece

276

DIMENSIONS

Width
86 cm · 33,9 in

Depth
12 cm · 4,7 in

Height
171 cm · 67,3 in

MATERIALS & FINISHES

Ref. [G702481](#)
FI094 Gold leaf; satin finish
EL001 LED light strip

TECHNICAL

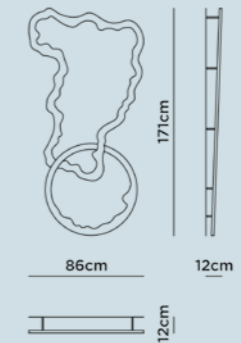

Ignis

Decorative Art Piece

278

DIMENSIONS

Width
100 cm · 39,4 in

Depth
22 cm · 8,7 in

Height
140 cm · 55,1 in

MATERIALS & FINISHES

Ref. [G702217](#)
FI001 Gold leaf; high-gloss
finish
ST042 Patagonia granite;
polished
GL011 Bronze glass

Ref. [G702858](#)
FI101 Grey lacquer;
satin finish
ST042 Patagonia granite;
polished
GL011 Bronze glass

TECHNICAL

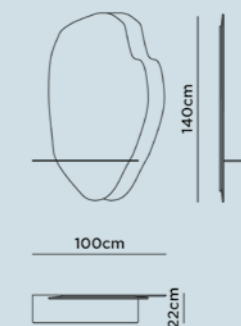

Sun and Sand

Decorative wall mirror

280

DIMENSIONS

Width
270 cm · 106,3 in

Depth
7 cm · 2,8 in

Height
126 cm · 49,6 in

MATERIALS & FINISHES

Ref. [G703104](#)
ME030 Brushed brass;
matt finish
MI001 Clear crystal mirror
FI025 Silver bronze powder;
high-gloss finish
ELO01 LED light strip

TECHNICAL

Breeze

Decorative wall piece

282

DIMENSIONS

Ø
140 cm · 55,1 in

Height
15 cm · 5,9 in

MATERIALS & FINISHES

Ref. [G703053](#)
FI148 Grey lacquer with a
textured effect; satin finish
ELO01 LED light strip

TECHNICAL

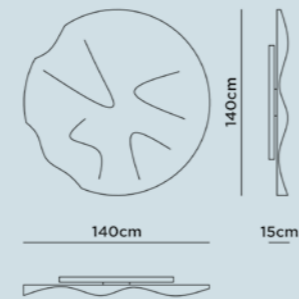

Moon

Decorative wall piece

285

DIMENSIONS

Ø
120 cm · 47,2 in

Depth
18 cm · 7,1 in

MATERIALS & FINISHES

Ref. [G702487](#)
FI147 Grey bronze powder
with a textured effect;
satin finish
AC001 Grey acrylic
ELO01 LED light strip

TECHNICAL

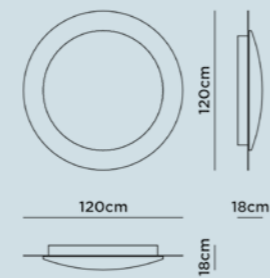

Tailored for you

We cut no corners,
your dream piece
begins with you.

From our product selection to the style of your home, dimensions, materials and fabrics can all be personalised, customised and manufactured to your individual specifications or your customers' own design.

Produtos customizados e personalizados

Em toda a nossa coleção de produtos, dimensões, materiais e tecidos podem ser personalizados, customizados e manufacturados de acordo com especificidades e requisitos do cliente.

Shape it,
make it
yours.

Big or small,
bespoke solutions that fit
with the client's specific needs.





**Personalise it,
make it
yours.**

Make it meaningful and memorable.
Give your living space that perfect,
unique and personalised touch
and make that your signature piece.

**Style it,
make it
yours.**

Green or yellow,
endless combinations to meet
all of your expectations.



Turnkey interior design projects

Each project begins with pencil, paper and a relaxed familiar environment.

Our in-house team of architects, designers and craftsmen is dedicated to deliver successful punctual projects and meet any design or procurement requirement to the highest quality standards. From planning, design, execution and installation, our customers enjoy a full bespoke interior project that includes a state-of-the-art workshop and limitless interactions between designers and makers.

Your journey starts here no matter you have an initial idea or want to create something truly unique.



Projetos de design de interiores

A nossa equipa de designers, arquitetos e artesãos assegura com sucesso a entrega de projetos chave na mão, cumprindo os tempos de entrega e requisitos, sempre com os mais altos padrões de qualidade.

É no nosso centro de produção e design, que todas as fases de projeto acontecem e assim beneficiam da proximidade entre as equipas envolvidas, resultando em interações ilimitadas e produtivas entre designers, artesãos e cliente.

Com uma intenção, ideia ou plano, iniciamos o seu projeto. A partir daqui a nossa equipa multidisciplinar estará focada em concretizar o seu sonho em algo único.

For project enquiries, please contact. Para mais informações acerca dos nossos projectos contacte-nos projects@greenapple.pt

Customer Product Support

Along with each product acquired by the client, we offer you our reliable and competent service staff that will ensure on-site any product assembly or installation.

Assistência ao cliente

Com cada produto adquirido, oferecemos um serviço competente de assistência, transporte, montagem e instalação no local providenciado pela nossa equipa.



Headquarters, Showroom & Production Unit

Located in Cartaxo, about
30 minutes from Lisbon.

Greenapple Portugal
Casal do Prioste, lote 1-Q
2070-034 Cartaxo,
Portugal

Opening hours
Monday to Friday
9 – 19 h

Telephone
+351 243 70 90 80

Whatsapp / Wechat
+351 967 952 518

Email
info@greenapple.pt

Web
www.greenapple.pt

Instagram
@greenapple.design.interiors